

# Yale

## Motorized Hand Reach Stacker

MRW020-E  
MRW030-E

**Yale** motorized hand trucks combine the latest in state-of-the-art technology and ergonomics making Yale the leader for masted walkie applications.

### Controls

Travel direction and speed are selected by rotating the actuator in the desired direction of travel. The butterfly throttle control provides multiple grip positions minimizing operator fatigue. The stationary portion of the handle minimizes wrist movement and provides a solid grip while maneuvering the truck. This assures additional stability while driving the truck. The bottom-mounted tiller handle optimizes the operating position.

Lift, Lower, Tilt, Reach/Retract and Horn push-buttons are conveniently located on the handle. Right hand push-buttons provide variable speed lift/lower for accurate load placement. Left hand push-buttons are used to control either single speed lift/lower or an optional sideshifter. Reach/retract control buttons are conveniently placed on the top center of the handle. Tilt is activated by depressing the shift button along with reach/retract buttons. The Traction Reversing Switch located on top of the handle simultaneously reverses truck direction and sounds the horn should it come in contact with the operator. The wrap around design provides protection through the full range of handle movement. This switch is reset when the direction control is returned to neutral or the handle is moved to the brake "on" position.

### Electrical System

The electrical system utilizes SEM technology with integral hoist control. Separately Excited Motor (SEM) provides the ability to control the traction motor fields and armature independently. This results in enhanced performance and battery efficiency. In combination with the Metal Oxide Semiconductor Field Effect Transistor (MOSFET) motor controller we have reduced wearable components, eliminated forward/reverse contactors and improved performance. The SEM control system provides higher top speeds when loaded and improved acceleration. The SEM control system provides higher top speeds when loaded and improved acceleration. Variable regenerative braking occurs when the throttle control is reversed. Regenerative braking improves traction motor brush life.

The controller has an Auto Deceleration System to decelerate the truck as the butterfly throttle is moved toward the neutral position. The controller senses when the truck is stopped and automatically applies the brake. The Auto Deceleration System reduces the need to manually apply a service brake for slow down. The controller has a programmable setup including parameters for acceleration, auto deceleration and top travel speed. Diagnostic information can be read using a hand-held programmer tool or by looking at the status of the LED indicator mounted on the controller. A solid-state circuit is used to control the pump motor and eliminates the lift contactor.

### User Selectable Performance Modes

The operator has a choice of three pre-programmed performance modes that are selectable through the tiller handle. These modes alter the acceleration, deceleration and top speed of the truck.

- Mode 1 – Economy mode (battery saver)
  - Soft acceleration; reduced top travel speed with auto deceleration adjusted

to a high level

- Mode 2 – Performance with auto deceleration
  - Medium acceleration; reduced top travel speed with auto deceleration adjusted to a high level
- Mode 3 – Performance with minimum auto deceleration
  - High acceleration; high top travel speed with auto deceleration adjusted to a minimum level

Adjustable performance modes enable the operator to optimize the performance of the truck to the particular work environment or the work cycle. The operator can select the desired mode using the controls on the handle. In addition, an optional "custom performance" mode is available and can be configured by your local Yale Dealer.

### Traction System

The traction system consists of the traction motor, gearbox, and brake. The UL approved traction motor with premium brushes and Class H insulation provides maximum thermal protection. The innovative gear box design incorporates maintenance-free steer bearings,

*(Continued on back page)*



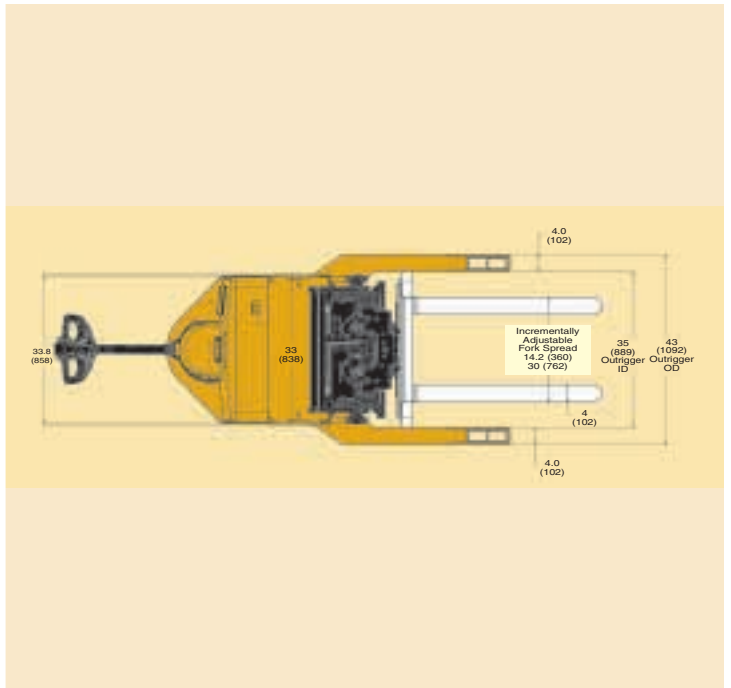
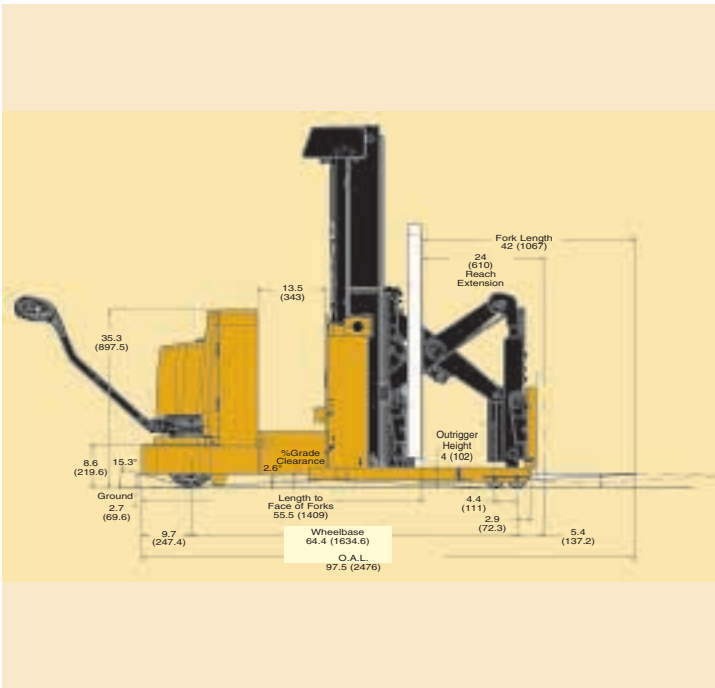

			GENERAL		
1	<b>Manufacturer</b>	Manufacturer Name		<b>Yale</b>	
2	<b>Model</b>	Manufacturer Designation		<b>MRW020-E</b>	
3	<b>Capacity</b>	Rated capacity	<b>lb. (kg)</b>	2000 (910)	
4	<b>Load Center</b>	Distance	<b>in. (mm)</b>	24 (610)	
5	<b>Power Type</b>	Gasoline, LPG, Diesel, Electric		Electric	
6	<b>Operator Type</b>	Pedestrian, Stand-on, Seated Rider		Pedestrian	
8	<b>Tire Type</b>	Cushion, Solid, Pneumatic, etc.		Cushion	
9	<b>Wheels</b>	Number - Drive / Load		1/4	
10-24	10	Lift Height (Top of Fork)	<b>in. (mm)</b>	123 (3124)	
		Standard Free Lift (Top of Fork)	<b>in. (mm)</b>	6.5 (165.1)	
	12	Maximum Carriage Width	<b>in. (mm)</b>	32.5 (825)	
	13	Forks	Thickness/Width/Length	<b>in. (mm)</b>	1.5 x 4.0 x 42
	14	Fork Spread	Outside Dimension - Max	<b>in. (mm)</b>	30.0 (772)
	15	Tilt of Mast	Backward/Forward	<b>degrees</b>	4/3
	16-19	Overall Dimensions	Length To Face of Forks		55.5 (1409)
			Outrigger ID	<b>in. (mm)</b>	35 (889) - 49 (1245)
			Lowered Overall Height (LOH)	<b>in. (mm)</b>	83 (2108.2)
			Maximum Fork Height (MFH)	<b>in. (mm)</b>	123 (3124)
	21	Turning Radius	Minimum (Outside)	<b>in. (mm)</b>	74.2 (1885)
	22	Overhang	End of Outrigger to Face of Forks	<b>in. (mm)</b>	2.6 (66)
	23	Right Angle Stack		<b>in. (mm)</b>	See Chart
	24	Intersecting Aisle		<b>in. (mm)</b>	See Chart
	Stability	Comply with ANSI?		Yes	
25-27	25	Voltage		24	
		Travel Speed Max - With load	<b>mph (kmh)</b>	3.1 (4.9)	
		No load		3.5 (5.6)	
		Lift Speed - With load	<b>ft./min (m/s)</b>	22 (.11)	
		No load		30 (.15)	
		Lowering Speed - With load	<b>ft./min (m/s)</b>	45 (.23)	
	No load		43 (.22)		
29	Gradeability		<b>%</b>	10	
31	Unloaded Weight	Standard Truck Without Battery	<b>lb. (kg.)</b>	3422 (1552)	
32	Axle Loads	No Load - Drive/Load with Min Battery	<b>lb. (kg.)</b>	2286 (1037) / 1736 (787)	
33-35	33	Tire Size		10" x 5" Poly	
		Drive Tire		10" x 5" Poly	
	34	Load Wheels		4.0" x 2.8" Tandem Poly	
	35	Wheelbase	Distance	<b>in. (mm)</b>	64.4 (1634.6)
37-38	37	Ground Clearance		0.5 (12.5)	
		No Load at Center of Wheelbase	<b>in. (mm)</b>	1.5 (38)	
41-43	41	Battery		24	
		Type		Lead Acid	
		Amphere Hours (Max)		510	
		Minimum Weight		600 (273)	
44-47	44	Electric Motors		2.3 (1.7)	
		Traction Motor - 60 Min Rating	<b>hp (Kw)</b>	4 (3)	
		Pump Motor - 15 min Rating	<b>hp (Kw)</b>	Transistor	
		Traction Motor Control Method		Infinitely Variable	
46	Number of Speeds			2900	
47	Relief Press		<b>psi</b>	13	
48	Grade Clearance	% Clearance 13.5" Comp	<b>%</b>	13	

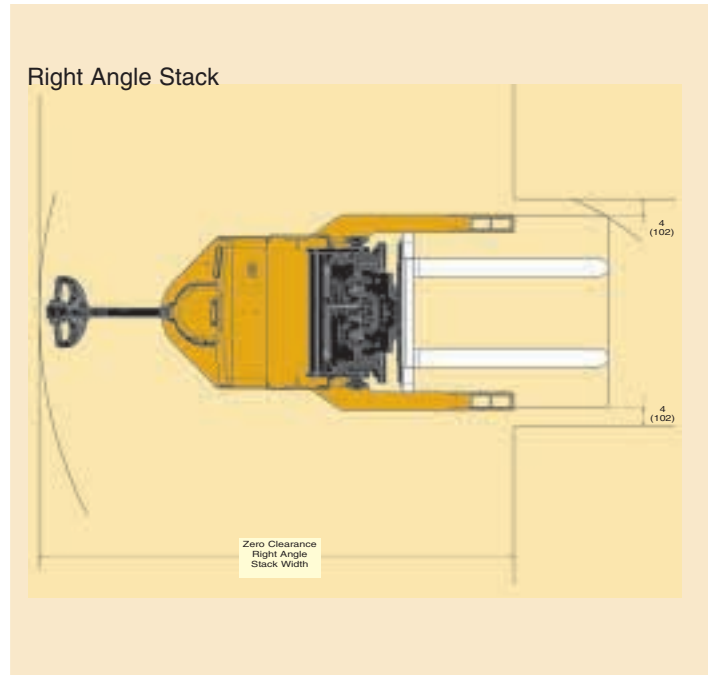
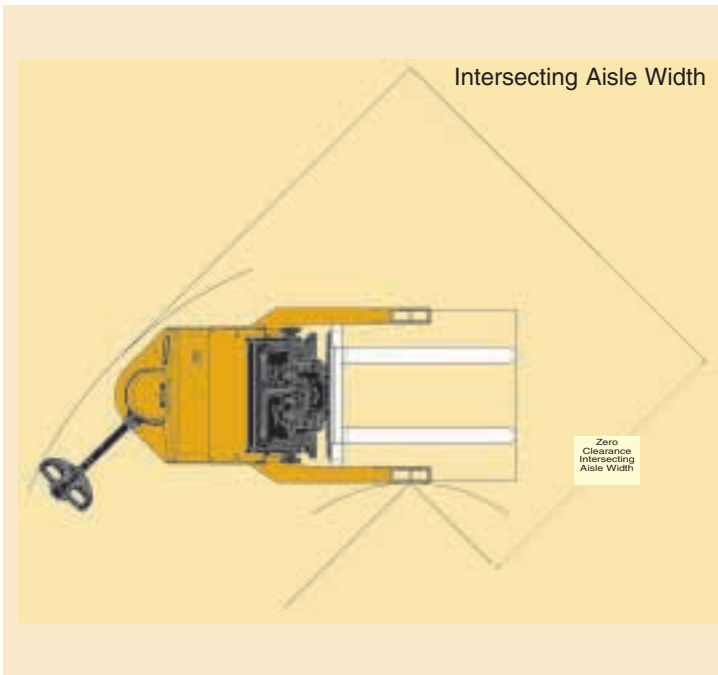

**Intersecting Equal Aisle  
2,000 – 3,000 Lbs. Capacity Reach Stacker**

Load Up and Over Outriggers					Load Between Outriggers				
Load Width	Load Length				Outrigger OAW	Load Length			
	36	40	42	48		36	40	42	48
36	63	63	63	63	44	69	69	69	69
40	65	65	65	65	48	71	71	71	71
41	65	65	65	65	49	71	71	71	71
42	66	66	66	66	50	71	71	71	71
48	69	69	69	69	57	74	74	74	74

**Note:** It is recommended to add a minimum 6"-12" for clearance.  
For triplex mast add 2"

**Right Angle Stack  
2,000 – 3,000 Lbs. Capacity Reach Stacker**

Load Width	Load Length			
	36	40	42	48
36	82	89	92	99
40	81	88	91	99
41	80	88	91	99
42	80	88	91	99
48	80	86	89	98

**Note:** It is recommended to add a minimum 6"-12" for clearance and stacking.  
For triplex mast add 2"

**Standard Specifications  
2,000 – 3,000 Lbs. Capacity Reach Stacker**

Load Width	Outrigger ID	OAW	Load Length	Fork Length	Wheelbase	OAL *	Length to Face of Forks
32	35	43	30-32	36	64.4	91.5	55.5
36	37	45	34-36	36	64.4	91.5	55.5
42	43	51	38-42	42	64.4	97.5	55.5
48	49	57	44-48	48	64.4	103.5	55.5

\*For triplex mast add 2"

**Standard Lift Specifications  
2,000 – 3,000 Lbs. Capacity Reach Stacker**  
For other available mast heights – contact your Yale Dealer

Lowered Overall Height	Lift Height	Free Lift	Extended Height
<b>MRW020-030-E SIMPLEX MASTS</b>			
72 (1829)	101 (2565)	6.5 (165)	149 (3785)
77 (1956)	111 (2819)		159 (4039)
83 (2108)	123 (3124)		171 (4343)
92 (2337)	141 (3581)		189 (4801)
<b>MRW020-030-E TRIPLEX MASTS</b>			
73 (1829)	149 (3810)	50 (1270)	197 (5004)
78 (1956)	164 (4166)	55 (1397)	212 (5385)
83 (2108)	179 (4547)	60 (1524)	227 (5766)

**Battery and Compartment Specifications  
2,000 – 3,000 Lbs. Capacity Reach Stacker**

No. of Cells	Cell Size	Plates per Cell	Capacity Amp-Hours	KWH	"X" Dim.	"Y" Dim.	"Z" Dim.	Weight
12	75	11	375	8.7	26.5	13.0	23.3	825 lbs.
12	85	11	425	9.9	26.1	12.8	23.3	865 lbs.
12	75	13	450	10.5	30.9	13.0	23.3	987 lbs.
12	85	13	510	11.9	30.9	13.0	23.3	1035 lbs.

**Notes:** 1) Steel tray with cover required for all batteries, 2) Battery connector type 175 Red (Gray is optional), 3) Cable lead position "B", 4) 20" cable length, 5) Maximum cable gauge of 1/0  
6) Battery well: 33" x 13.5" x open

(Continued from front page)

a stationary mounted traction motor, integrated motor pinion, and drive axle string guard. The maintenance-free steer bearings are sealed within the gearbox housing and lubricated by the gear oil. The stationary traction motor eliminates power cable tension and flex. The integral pinion and support bearings optimize the gear mesh resulting in a quieter gearbox. The splined coupling allows for quick removal and installation of the traction motor. The drive axle string guard minimizes axle seal damage from shrink-wrap, banding, etc.

The electronically released, mechanically applied brake is on top of the traction motor for ease of inspection and maintenance. The brake is controlled by a handle position switch which prevents the truck from moving when the tiller handle is fully raised or fully lowered.

### Reach Mechanism

The reach mechanism is computer designed and provides 24 inches of extension. The open carriage design and optimal hose routing provide good visibility. Carriage, load backrest, hook type forks, and optional integral sideshifter all tilt and sideshift together. Reach/retract cylinders are fully cushioned for smooth operation. All pivot points have high pressure grease fittings for lubrication. Dual tilt cylinders are used to evenly distribute the load.

### Mast, Carriage and Forks

The Yale mast is available in simplex and triplex configurations for various heights. The trunnion mounted mast design provides for good load distribution and allows for easy service and transport. The hydraulic cylinder incorporates a chrome-plated rod for corrosion resistance. The cylinders are easily serviced and provide integral cushioning for excellent mast channel staging. Velocity fuses are provided to control lowering in the

event of hydraulic failure. A manual lowering valve is standard. The standard tilting carriage provides 4° backward/3° forward tilt. Lowering speeds are controlled by a valve in the manifold block. Controlled descent is assured by velocity fuses in each cylinder base. Forks are heat-treated, forged steel with increased thickness in the critical heel section.

### Wheels and tires

The standard load wheel configuration is tandem poly load wheels with two roller bearings per wheel. "Knock-out" axles provide for quick and easy maintenance. The load wheel compound is 92 durometer polyurethane molded over a steel wheel and the wheel measures 4" X 2.8".

A 10" X 5" press-on poly drive tire is standard. The drive wheel is secured to the axle with 5 bolts.

### Additional Features

- Lubrication – Fill and drain plugs are provided
- Battery connector – Standard is (red) 175 amp connector
- Standard equipment includes key switch and an electronic horn
- 48" load backrest is standard

### Options

- Cold storage/freezer package to -15° F
- Multi-function display with BDI, hour meter and fault light
- Integral sideshifter (3.5" each side of center)
- Various mast heights
- Lexan transparent mast shield
- Creep speed control
- Various fork lengths
- Keyless toggle ignition switch
- 10" X 5" rubber drive tire
- Battery rollers (11.4" from floor to top of rollers)

**Truck performance may be affected by the condition of the vehicle, how it is equipped, and the application. Consult your Yale Industrial Truck Dealer if any of the information shown is critical to your application. Specifications are subject to change without notice.**

**This truck meets all design specifications of ANSI B56.1 Safety Standard for Powered Industrial Trucks at the time of manufacture. Classified by Underwriters' Laboratories, Inc. as to fire hazard only for Type E industrial trucks.**