



# GP-VX

## VERACITOR® PNEUMATIC TIRE TRUCKS

6,000 · 7,000 lbs

### Yale Veracitor® GP-VX Series

This series of trucks is available in several configurations, designed to meet and exceed your material handling application requirements. The Veracitor® forklift can be configured for maximum performance and lowest cost of operation for medium to heavy duty applications with state-of-the-art features and superior power. The innovative Yale® Flex Performance Technology™ offers selectable performance modes that provide the flexibility to maximize fuel economy or productivity to match application needs.

### Yale Veracitor® VX Industrial Engines

feature a rigid cast iron block and main bearing caps. The nodular iron crankshaft is supported with five main bearings. All engines include hardened exhaust valve seats with stellite coated valves for superior durability and electronic throttle control for precise performance and consistent operation. Both Kubota engines feature a cast iron cylinder head as well as a long cylinder stroke for improved torque. The PSI and Kubota LPG engines feature coil over plug ignition design which eliminates spark plug wires.

The PSI engines feature twin engine balance shafts to reduce engine vibration resulting in smoother and quieter performance.

The Kubota 2.4L diesel cylinder heads feature a helical, “crossflow” design within each cylinder to create additional airflow into the cylinder for added power. The turbocharger is a simple design, but uses a variable waste-gate to ensure the proper amount of boost at all engine speeds. The charge air cooler (intercooler) helps lower emissions and increase power by cooling the hot air as it exits the turbocharger and enters the intake manifold.

### Fuel Systems

All engines are EPA emissions compliant. The PSI and Kubota LPG engines feature closed loop emissions regulation systems that continually monitor exhaust and adjust fuel/air mix as necessary. These engines use a mixer carburetor and a vaporizer/regulator to convert fuel from a liquid to a gas.

The Kubota EPA Certified Tier 4 Final diesel fuel system utilizes an electronically controlled, high-pressure common-rail fuel system that sends five individual fuel injections per power stroke for maximum power and efficiency while reducing noise levels. A cooled Exhaust Gas Recirculation

(EGR) system recycles a portion of the exhaust to be re-burned and reduce emissions, along with a diesel oxidation catalyst (DOC) that continuously oxidizes particulate matter (soot) with no effect on truck operation.

### Transmission

There are two transmission selections available with multiple engine configurations that will handle a wide variety of material handling applications. Both transmissions feature electronic inching (requires no adjustment), electronic shift control, neutral start switch, and anti-restart protection. The Techtronix 100 features auto deceleration through the controlled application of clutch packs, and also reduces tire spin by precisely regulating engine speed during controlled power reversals. A single pedal controls both inching and braking. Optional dual inch/brake pedals are available for operators who prefer this design. A 10 micron filter protects the transmission from abrasive contaminants.

**Cooling System** employs a 17” blade pusher-type fan. A high capacity, cross-flow radiator ensures rapid heat dissipation. The sealed cooling system operates at a pressure of 15 psi and includes a coolant recovery tank for visual inspection of coolant level. The transmission oil cooler is integrated into the radiator and is located in the side tank. The optional combi-cooler radiator features an externally mounted transmission oil cooler for increased heat transfer capability. All radiators are soft-mounted for excellent durability.

### Drive Axle

The drive axles are designed to withstand heavy duty loads and absorb shock loads. The wheel hubs rotate on large tapered roller bearings. The drive shaft transmits torsion to the drive axle from the engine and transmission. Transmission torque occurs through an industrial hypoid ring gear and pinion differential assembly.

The drive axle is a self contained assembly that is isolated from the transmission by a heavy duty rubber isolator. The axle shafts utilize a “rolled fillet” root spline design for increased resistance to

### LPG/Dual Fuel Engine Specifications

|              |                      |
|--------------|----------------------|
| Engine       | PSI 2.4L             |
| Cylinders    | 4                    |
| Camshaft     | Overhead Valve       |
| Displacement | 143 cu.in/2.4 liter  |
| Torque       | 121 lb.ft @ 2000 RPM |
| Horsepower   | 59 hp                |

### LP Engine Specifications

|                  |                      |
|------------------|----------------------|
| Engine           | Kubota 2.5L          |
| Cylinders        | 4                    |
| Camshaft         | Overhead Valve       |
| Displacement     | 152 cu.in/2.5 liter  |
| Torque           | 131 lb.ft @ 1000 RPM |
| Horsepower       | 59 @ 2500 rpm        |
| Air Filtration   | Two stage, Dry Type  |
| Emission Control | Closed Loop          |

### Diesel Engine Specifications

|              |                          |
|--------------|--------------------------|
| Engine       | Kubota 2.4L Turbo Diesel |
| Cylinders    | 4                        |
| Camshaft     | Overhead Valve           |
| Displacement | 149 cu.in/2.4 liter      |
| Torque       | 146 @ 1500 RPM           |
| Horsepower   | 57hp                     |

torsion stress. A magnetic sump plug is used to collect any metal particles that are circulating in the axle oil, preventing excessive component wear.

### Hydraulic Brakes

Asbestos-free self-adjusting brake linings are bonded to steel shoes and act against cast iron drums. Single circuit master cylinder has a sealed fluid reservoir and features a fluid level sensor which activates an indicator light located

*(continued on back)*



Truck shown with optional equipment

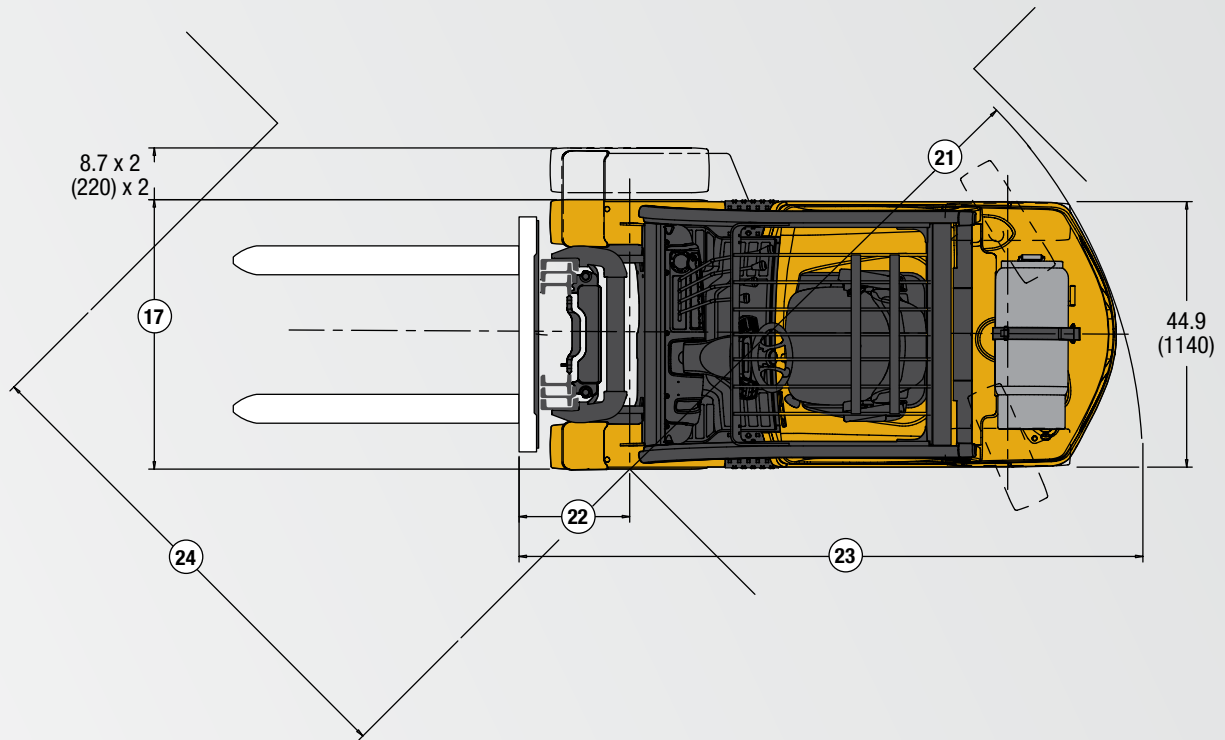

|                  | Non-Susp    | Semi        | Full        | Swivel Full |
|------------------|-------------|-------------|-------------|-------------|
|                  | in (mm)     | in (mm)     | in (mm)     | in (mm)     |
| Tall OHG (Std.)  | 42.0 (1068) | 42.5 (1080) | 42.0 (1068) | 41.7 (1062) |
| Short OHG (Opt.) | 39.4 (1001) | 39.9 (1013) | N/A         | N/A         |

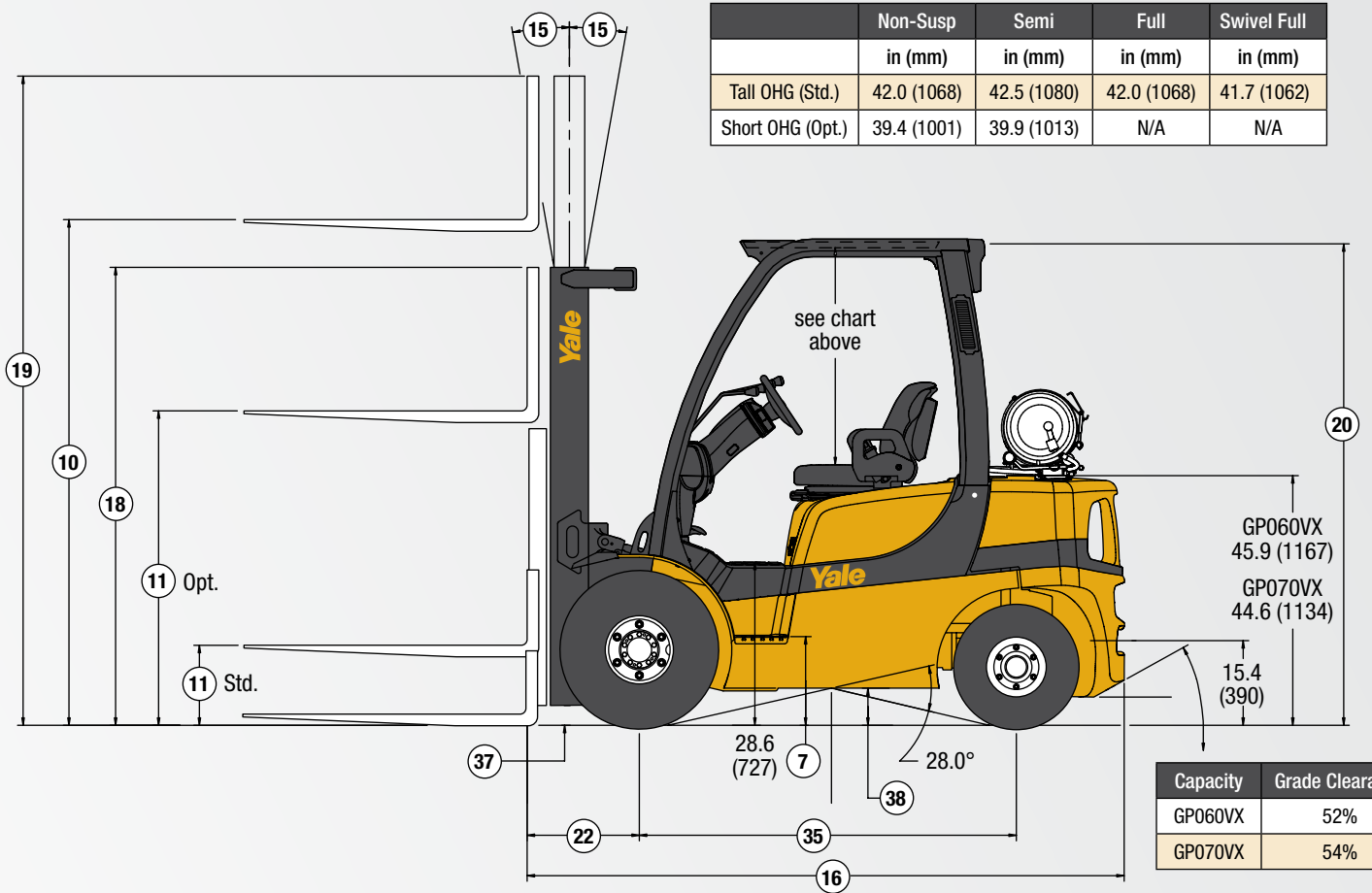

GP060VX  
45.9 (1167)  
GP070VX  
44.6 (1134)

| Capacity | Grade Clearance |
|----------|-----------------|
| GP060VX  | 52%             |
| GP070VX  | 54%             |

|                |   |  |   |                       |                       |                          |                       |
|----------------|---|--|---|-----------------------|-----------------------|--------------------------|-----------------------|
| GENERAL        | 1   | Manufacturer Name  |   | Yale                  |                       |                          |                       |
|                | 2   | Model  |   | GP060VX               |                       |                          |                       |
|                |   | Engine   |   | PSI 2.4L              | Kubota 2.5L           | Kubota 2.4L Tier 4 Final |                       |
|                | 3   | Rated Capacity   | lb (kg)                                     | 6000 (2722)           |                       |                          |                       |
|                | 4   | Load Center, Distance  | in (mm)                                     | 24.0 (610)            |                       |                          |                       |
|                | 5   | Power Type - LPG, Diesel, Dual Fuel                          |   | LPG                   | Dual Fuel             | LPG                      | Diesel                |
|                | 6   | Operator Type  |   | Sit-Down Rider        |                       |                          |                       |
|                | 7   | Step Height  | in (mm)                                     | 16 (407)              |                       |                          |                       |
|                | 8   | Tire Type - Cushion, Solid, Pneumatic                        |   | Pneumatic             |                       |                          |                       |
| DIMENSIONS     | 9   | Wheels, Number - Front/ Rear                                 |   | 2x/2                  |                       |                          |                       |
|                | 10  | Lift Height, Top of Fork (TOF)                               | in (mm)                                     | 126 (3209)            |                       |                          |                       |
|                | 11  | Lift Heights, Standard Limited Free Lift (LFL) w/o LBR (TOF) | in (mm)                                     | 5 (140)               |                       |                          |                       |
|                |   | Lift Heights, Optional Full Free Lift (FFL) w/o LBR (TOF)    | in (mm)                                     | 59 (1500)             |                       |                          |                       |
|                | 12  | Standard Carriage Width                                      | in (mm)                                     | 42 (1067)             |                       |                          |                       |
|                | 13  | Forks, Thickness x Width x Length                            | in  | 2.0 X 4.9 X 42        |                       |                          |                       |
|                |   | Forks, Thickness x Width x Length                            | (mm)  | (50 X 125 X 1067)     |                       |                          |                       |
|                | 14  | Fork Spread, Outside Dimensions                              | in (mm)                                     | 43.3 (1099)           |                       |                          |                       |
|                | 15  | Mast Tilt Angles, Forward/Backward                           | degrees                                     | 6F/6B                 |                       |                          |                       |
|                | 16  | Length To Face of Forks                                      | in (mm)                                     | 103.4 (2625)          |                       |                          |                       |
|                | 17  | Overall Width, Standard Tread                                | in (mm)                                     | 46.7 (1186)           |                       |                          |                       |
|                |   | Overall Width, Wide Tread                                    | in (mm)                                     | 52.0 (1321)           |                       |                          |                       |
|                | 18  | Height, Standard Mast - Lowered                              | in (mm)                                     | 89 (2245)             |                       |                          |                       |
|                | 19  | Height, Standard Mast - Extended with LBR                    | in (mm)                                     | 175 (4330)            |                       |                          |                       |
|                |   | Height, Standard Mast - Extended without LBR                 | in (mm)                                     | 154 (3905)            |                       |                          |                       |
|                | 20  | Height, Standard Overhead Guard                              | in (mm)                                     | 86.0 (2185)           |                       |                          |                       |
|                |   | Height, Optional Overhead Guard                              | in (mm)                                     | 83 (2118)             |                       |                          |                       |
|                | 21  | Turning Radius, Minimum Outside (OTR)                        | in (mm)                                     | 89.6 (2277)           |                       |                          |                       |
|                | 22  | Length, Center of Wheel to Face of Forks                     | in (mm)                                     | 18.9 (480)            |                       |                          |                       |
|                | 23  | Aisle Width, Right Angle Stack (Add Length of Load)          | in (mm)                                     | 108.5 (2757)          |                       |                          |                       |
|                | 24  | Equal Aisle, 90-Degree Intersecting Aisle                    | in (mm)                                     | 82.8 (2077)           |                       |                          |                       |
|                | PERFORMANCE                                       | 25   | Travel Speed, Powershift Transmission RL/NL | mph (km/h)            | 11.8/12.4 (19.0/20.0) | 11.1/11.3 (17.8/18.2)    | 11.9/12.1 (19.2/19.5) |
|                |   | 26   | Lift Speed, Standard 2-Stage LFL RL/NL      | ft/min (m/s)          | 104/108 (.53/.55)     | 108/110 (.55/.56)        | 108/110 (.55/.56)     |
|                |   |  | Lift Speed, Optional 2-Stage FFL RL/NL      | ft/min (m/s)          | 102/102 (.52/.52)     | 104/106 (.53/.54)        | 104/106 (.53/.54)     |
|                |   | Lift Speed, Optional 3-Stage FFL RL/NL                       | ft/min (m/s)                                | 100/104 (.51/.53)     | 100/104 (.51/.53)     | 100/104 (.51/.53)        |                       |
| 27             |   | Lowering Speed, Standard 2-Stage LFL RL/NL                   | ft/min (m/s)                                | 104/93 (.53/.47)      |                       |                          |                       |
|                |   | Lowering Speed, Optional 2-Stage FFL RL/NL                   | ft/min (m/s)                                | 98/83 (.50/.42)       |                       |                          |                       |
|                |   | Lowering Speed, Optional 3-Stage FFL RL/NL                   | ft/min (m/s)                                | 114/87 (.58/.44)      |                       |                          |                       |
| 28             |   | Maximum drawbar pull RL/NL                                   | lb (kg)                                     | 4497/2346 (2040/1064) | 4530/2346 (2055/1064) | 4680/2346 (2120/1064)    |                       |
|                |   | Drawbar Pull, Standard Transmission @ 1 mph RL/NL            | lb (kg)                                     | 3845/2346 (1744/1064) | 3920/2346 (1778/1064) | 4330/2346 (1960/1064)    |                       |
| 29             | Gradeability, Standard Transmission @ 1 mph RL/NL | Percent %  | 25/26                                       | 26/26                 | 27/26                 |                          |                       |
| WT.            | 31  | Weight, Standard Truck (2-Stg. LFL) NL                       | lb (kg)                                     | 9943 (4510)           |                       |                          |                       |
|                |   | Weight, Standard Truck (2-Stg. LFL) RL                       | lb (kg)                                     | 15943 (7232)          |                       |                          |                       |
|                | 32  | Axle Loading, Static Front/Rear NL                           | lb (kg)                                     | 3865/6077 (1753/2757) |                       |                          |                       |
|                |   | Axle Loading, Static Front/Rear RL                           | lb (kg)                                     | 13905/2038 (6307/924) |                       |                          |                       |
| TIRES & WHEELS | 33  | Tire Size, Front   |   | 28 x 9 - 15           |                       |                          |                       |
|                | 34  | Tire Size, Rear  |   | 6.50 x 10             |                       |                          |                       |
|                | 35  | Wheelbase  | in (mm)                                     | 63.9 (1623)           |                       |                          |                       |
|                | 37  | Ground Clearance, Lowest Point NL (w/RL subtract-6mm)        | in (mm)                                     | 6.2 (157)             |                       |                          |                       |
|                | 38  | Ground Clearance, Center of Wheelbase NL                     | in (mm)                                     | 6.3 (160)             |                       |                          |                       |
|                | 39  | Service Brake - Method of Control/Operation                  |   | Foot/Hydraulic        |                       |                          |                       |
|                | 40  | Parking Brake - Method of Control/Operation                  |   | Hand/Mechanical       |                       |                          |                       |
| POWERTRAIN     | 41  | Battery Type   |   | Maintenance Free      |                       |                          |                       |
|                | 42  | Volts/Cold Cranking Amps                                     | v/cca                                       | 12/475                |                       | 12/770                   |                       |
|                | 43  | Engine, Manufacturer/Model                                   |   | PSI 2.4L              | Kubota 2.5L           | Kubota 2.4L              |                       |
|                | 44  | Permanent Output   | hp (kw)                                     | 59 (44)               | 59 (44)               | 57 (43)                  |                       |
|                | 45  | Torque @ Rated RPM   | ft Lbs (kg/m)                               | 121 (16.7) @ 2700 RPM | 131 (18) @ 1000 RPM   | 146 (20) @ 1500 RPM      |                       |
|                | 46  | Number of Cylinders/Displacement                             | No/cc (ci)                                  | 4/2351 (143)          | 4/2491 (152)          | 4/2434 (149)             |                       |
|                | 47  | Transmission Type, Standard                                  |   | Electronic Powershift |                       |                          |                       |
|                |   | Standard Speeds, Forward - Reverse                           |   | 1-1                   |                       |                          |                       |
|                | 49  | Hydraulic Tank Capacity (Drain and Refill)                   | gal (liter)                                 | 12.1 (45.8)           |                       |                          |                       |
|                | 50  | Fuel Tank Capacity (Gas & Diesel Powered Units Only)         | gal (liter)                                 | 13.9 (52.8)           |                       |                          |                       |
|                | 51  | Auxiliary Hydraulic Pressure Relief for Attachments          | PSI (Mpa)                                   | 2250 (15.5)           |                       |                          |                       |

|                |   |  |   |                       |                       |                          |                       |
|----------------|---|--|---|-----------------------|-----------------------|--------------------------|-----------------------|
| GENERAL        | 1   | Manufacturer Name  |   | Yale                  |                       |                          |                       |
|                | 2   | Model  |   | GP070VX               |                       |                          |                       |
|                |   | Engine   |   | PSI 2.4L              | Kubota 2.5L           | Kubota 2.4L Tier 4 Final |                       |
|                | 3   | Rated Capacity   | lb (kg)                                     | 7000 (3175)           |                       |                          |                       |
|                | 4   | Load Center, Distance  | in (mm)                                     | 24.0 (610)            |                       |                          |                       |
|                | 5   | Power Type - LPG, Diesel, Dual Fuel                          |   | LPG                   | Dual Fuel             | LPG Diesel               |                       |
|                | 6   | Operator Type  |   | Sit-Down Rider        |                       |                          |                       |
|                | 7   | Step Height  | in (mm)                                     | 16.0 (407)            |                       |                          |                       |
|                | 8   | Tire Type - Cushion, Solid, Pneumatic                        |   | Pneumatic             |                       |                          |                       |
| DIMENSIONS     | 9   | Wheels, Number - Front/ Rear                                 |   | 2x/2                  |                       |                          |                       |
|                | 10  | Lift Height, Top of Fork (TOF)                               | in (mm)                                     | 126 (3209)            |                       |                          |                       |
|                | 11  | Lift Heights, Standard Limited Free Lift (LFL) w/o LBR (TOF) | in (mm)                                     | 5 (140)               |                       |                          |                       |
|                |   | Lift Heights, Optional Full Free Lift (FFL) w/o LBR (TOF)    | in (mm)                                     | 59 (1500)             |                       |                          |                       |
|                | 12  | Standard Carriage Width                                      | in (mm)                                     | 42 (1067)             |                       |                          |                       |
|                | 13  | Forks, Thickness x Width x Length                            | in  | 2.0 X 4.9 X 42        |                       |                          |                       |
|                |   | Forks, Thickness x Width x Length                            | (mm)  | (50 X 125 X 1067)     |                       |                          |                       |
|                | 14  | Fork Spread, Outside Dimensions                              | in (mm)                                     | 43.3 (1099)           |                       |                          |                       |
|                | 15  | Mast Tilt Angles, Forward/Backward                           | degrees                                     | 6F/6B                 |                       |                          |                       |
|                | 16  | Length To Face of Forks                                      | in (mm)                                     | 107.6 (2734)          |                       |                          |                       |
|                | 17  | Overall Width, Standard Tread                                | in (mm)                                     | 46.7 (1186)           |                       |                          |                       |
|                |   | Overall Width, Wide Tread                                    | in (mm)                                     | 52.0 (1321)           |                       |                          |                       |
|                | 18  | Height, Standard Mast - Lowered                              | in (mm)                                     | 89 (2245)             |                       |                          |                       |
|                | 19  | Height, Standard Mast - Extended with LBR                    | in (mm)                                     | 175 (4330)            |                       |                          |                       |
|                |   | Height, Standard Mast - Extended without LBR                 | in (mm)                                     | 154 (3905)            |                       |                          |                       |
|                | 20  | Height, Standard Overhead Guard                              | in (mm)                                     | 86 (2185)             |                       |                          |                       |
|                |   | Height, Optional Overhead Guard                              | in (mm)                                     | 83 (2118)             |                       |                          |                       |
|                | 21  | Turning Radius, Minimum Outside (OTR)                        | in (mm)                                     | 93.7 (2380)           |                       |                          |                       |
|                | 22  | Length, Center of Wheel to Face of Forks                     | in (mm)                                     | 18.9 (480)            |                       |                          |                       |
|                | 23  | Aisle Width, Right Angle Stack (Add Length of Load)          | in (mm)                                     | 112.6 (2860)          |                       |                          |                       |
|                | 24  | Equal Aisle, 90-Degree Intersecting Aisle                    | in (mm)                                     | 84 (2111)             |                       |                          |                       |
|                | PERFORMANCE                                       | 25   | Travel Speed, Powershift Transmission RL/NL | mph (km/h)            | 11.8/12.4 (19.0/20.0) | 11.1/11.3 (17.8/18.2)    | 11.9/12.1 (19.2/19.5) |
|                |   | 26   | Lift Speed, Standard 2-Stage LFL RL/NL      | ft/min (m/s)          | 104/108 (.53/.55)     | 110/110 (.56/.56)        | 110/110 (.56/.56)     |
|                |   |  | Lift Speed, Optional 2-Stage FFL RL/NL      | ft/min (m/s)          | 102/102 (.52/.52)     | 104/106 (.53/.54)        | 104/106 (.53/.54)     |
|                |   | Lift Speed, Optional 3-Stage FFL RL/NL                       | ft/min (m/s)                                | 100/104 (.51/.53)     | 102/104 (.52/.53)     | 102/104 (.52/.53)        |                       |
| 27             |   | Lowering Speed, Standard 2-Stage LFL RL/NL                   | ft/min (m/s)                                | 104/93 (.53/.47)      |                       |                          |                       |
|                |   | Lowering Speed, Optional 2-Stage FFL RL/NL                   | ft/min (m/s)                                | 98/83 (.50/.42)       |                       |                          |                       |
|                |   | Lowering Speed, Optional 3-Stage FFL RL/NL                   | ft/min (m/s)                                | 114/87 (.58/.44)      |                       |                          |                       |
| 28             |   | Maximum drawbar pull RL/NL                                   | lb (kg)                                     | 4465/2317 (2025/1051) | 4500/2317 (2041/1051) | 4650/2317 (2110/1051)    |                       |
|                |   | Drawbar Pull, Standard Transmission @ 1 mph RL/NL            | lb (kg)                                     | 3810/2317 (1730/1051) | 3887/2317 (1763/1051) | 4300/2317 (1950/1051)    |                       |
| 29             | Gradeability, Standard Transmission @ 1 mph RL/NL | Percent %  | 22/24                                       | 23/24                 | 24/24                 |                          |                       |
| WT.            | 31  | Weight, Standard Truck (2-Stg. LFL) NL                       | lb (kg)                                     | 10357 (4698)          |                       |                          |                       |
|                |   | Weight, Standard Truck (2-Stg. LFL) RL                       | lb (kg)                                     | 17356 (7873)          |                       |                          |                       |
|                | 32  | Axle Loading, Static Front/Rear NL                           | lb (kg)                                     | 3810/6547 (1728/2970) |                       |                          |                       |
|                |   | Axle Loading, Static Front/Rear RL                           | lb (kg)                                     | 15304/2052 (6942/931) |                       |                          |                       |
| TIRES & WHEELS | 33  | Tire Size, Front   |   | 28 x 9 - 15           |                       |                          |                       |
|                | 34  | Tire Size, Rear  |   | 6.50 x 10             |                       |                          |                       |
|                | 35  | Wheelbase  | in (mm)                                     | 66.9 (1700)           |                       |                          |                       |
|                | 37  | Ground Clearance, Lowest Point NL (w/RL subtract-6mm)        | in (mm)                                     | 6.2 (157)             |                       |                          |                       |
|                | 38  | Ground Clearance, Center of Wheelbase NL                     | in (mm)                                     | 7.3 (185)             |                       |                          |                       |
|                | 39  | Service Brake - Method of Control/Operation                  |   | Foot/Hydraulic        |                       |                          |                       |
|                | 40  | Parking Brake - Method of Control/Operation                  |   | Hand/Mechanical       |                       |                          |                       |
| POWERTRAIN     | 41  | Battery Type   |   | Maintenance Free      |                       |                          |                       |
|                | 42  | Volts/Cold Cranking Amps                                     | v/cca                                       | 12/475                |                       | 12/770                   |                       |
|                | 43  | Engine, Manufacturer/Model                                   |   | PSI 2.4L              | Kubota 2.5L           | Kubota 2.4L              |                       |
|                | 44  | Permanent Output   | hp (kw)                                     | 59 (44)               | 59 (44)               | 57 (43)                  |                       |
|                | 45  | Torque @ Rated RPM   | ft Lbs (kg/m)                               | 121 (16.7) @ 2700 RPM | 131 (18) @ 1000 RPM   | 146 (20) @ 1500 RPM      |                       |
|                | 46  | Number of Cylinders/Displacement                             | No/cc (ci)                                  | 4/2351 (143)          | 4/2491 (152)          | 4/2434 (149)             |                       |
|                | 47  | Transmission Type, Standard                                  |   | Electronic Powershift |                       |                          |                       |
|                |   | Standard Speeds, Forward - Reverse                           |   | 1-1                   |                       |                          |                       |
|                | 49  | Hydraulic Tank Capacity (Drain and Refill)                   | gal (liter)                                 | 12.1 (45.8)           |                       |                          |                       |
|                | 50  | Fuel Tank Capacity (Gas & Diesel Powered Units Only)         | gal (liter)                                 | 13.9 (52.8)           |                       |                          |                       |
|                | 51  | Auxiliary Hydraulic Pressure Relief for Attachments          | PSI (Mpa)                                   | 2250 (15.5)           |                       |                          |                       |



| GP060-070VX MAST DIMENSIONS                                     |                        |                         |             |                 |             |   |              |
|---|------------------------|-------------------------|-------------|-----------------|-------------|---|--------------|
| Maximum Fork Height (TOF) †                                     | Overall Lowered Height | Overall Extended Height |             | Free Lift (TOF) |             | Approximate Total Weight of Standard Equipped Truck |              |
|   |                        | with LBR                | without LBR | with LBR        | without LBR | GP060VX   | GP070VX      |
| in (mm)   | in (mm)                | in (mm)                 | in (mm)     | in (mm)         | in (mm)     | lbs (kg)  | lbs (kg)     |
| <b>2-STAGE LIMITED FREE LIFT (LFL) Hi-Vis™<sub>2</sub> MAST</b> |                        |                         |             |                 |             |   |              |
| 126 (3209)  | 89 (2245)              | 175 (4430)              | 154 (3905)  | 5 (150)         | 5 (150)     | 9943 (4510)   | 10357 (4698) |
| <b>2-STAGE FULL FREE LIFT (FFL) Hi-Vis™ MAST</b>                |                        |                         |             |                 |             |   |              |
| 122 (3110)  | 87 (2195)              | 171 (4335)              | 150 (3805)  | 37 (965)        | 59 (1500)   | 9957 (4516)   | 10371 (4704) |
| 130 (3310)  | 91 (2295)              | 179 (4535)              | 158 (4005)  | 38 (975)        | 63 (1600)   | 9994 (4533)   | 10408 (4721) |
| <b>3-STAGE FULL FREE LIFT (FFL) Hi-Vis™<sub>2</sub> MAST</b>    |                        |                         |             |                 |             |   |              |
| 181 (4618)  | 87 (2195)              | 230 (5840)              | 208 (5260)  | 37 (965)        | 63 (1600)   | 10307 (4675)  | 10721 (4863) |
| 187 (4768)  | 91 (2295)              | 236 (5990)              | 213 (5410)  | 41 (1065)       | 65 (1655)   | 10352 (4696)  | 10766 (4883) |
| 211 (5368)  | 101 (2545)             | 260 (6590)              | 237 (6010)  | 51 (1315)       | 75 (1905)   | 10481 (4754)  | 10894 (4942) |
| 228 (5818)  | 107 (2695)             | 278 (7040)              | 256 (6495)  | 57 (1465)       | 80 (2055)   | 10662 (4836)  | 11076 (5024) |

† Lift heights over 171.5" (4356 mm) maximum fork height are considered highlifts and require reduced capacity and restricted back tilt. Total approximate weights listed include mast, standard carriage, load backrest (LBR) and 70 lbs. LPG tank and tank bracket.



(continued from cover)

on the instrument panel. Independent, hand adjustable parking brake with push-button release has an audible alarm.

#### **Wet Disc Brakes**

Optional oil-cooled wet disc brakes provide excellent stopping power with an extremely long service life. The brake cooling oil circulates within the axle to provide consistent braking performance with no fade or change in pedal effort or travel, throughout the entire shift and beyond.

**Hydrostatic Power Steering** provides responsive control and eliminates mechanical linkages for reduced surface shock and simplified maintenance. The steering wheel is 12 inches in diameter with a textured surface grip and spinner knob, and requires only four turns lock-to-lock. The center mounted steer cylinder is located within the confines of the steer axle for protection.

**Steer Axle** is constructed of cast steel and is rubber shock mounted to the frame for reduced wear and vibration. The Continuous Stability System (CSS™) enhances lateral truck stability through reduced steer axle articulation, while simultaneously allowing travel across various surfaces.

**Chassis** designed by Finite Element Analysis (FEA) methods contains a rugged, unitized frame structure with a low step for simple entrance to the operator's compartment. Ergonomically designed overhead guard is bar type for great visibility and reduced noise.

**Operator's Compartment** features cowl-mounted hydraulic control levers positioned on the right side of the steering column. Optional Accutouch electro-hydraulic controls are integrated into the operator's right-side armrest allowing superior ergonomic actuation. A pedal arrangement with a large, single inch/brake pedal is standard. Tilt cylinders are located beneath the floor for uncluttered space. Rubber floor mat reduces noise and vibration. Floorplate can be removed without tools for excellent service access. Low step height and a convenient hand grip provide easy entry and exit to and from the truck.

**Intellix VSM** acts as a master truck controller, providing extensive monitoring and control of truck functions and systems. CANbus technology reduces wiring complexity and enables comprehensive communications between truck systems. The ergonomically positioned dash display transmits continual feedback to the operator and allows for communication of service codes. Comprehensive on-board diagnostics enable quick and easy troubleshooting. The electrical system features sealed connectors and Hall Effect sensors for superior dependability.

**Hydraulic System** incorporates a gear type pump, cast iron body for quiet efficiency. The system is protected from overloads by a main relief valve for the lift circuit and a secondary relief valve for tilt and auxiliary functions. Oil is double filtered through a 100 mesh suction line strainer and 10 micron return line filter. The hydraulic tank is integrated into the frame. An emergency lowering valve is provided to allow the load to be lowered in the event of power loss. O-ring face seal fittings are used in all high pressure hydraulic connections.

**Yale Hi-Vis™ Masts** are available in 2-stage LFL (Hi-Vis™<sub>2</sub>), 2-stage FFL (Hi-Vis™), and 3-stage FFL (Hi-Vis™<sub>2</sub>) models. Mast features flush-faced design with geometrically matched, angled load roller bearings which are canted, yet provide full-face roller contact. The mast front rail flange angle coupled with the inverted "J" inner channel and three degree mast rollers significantly reduce channel and roller wear. "J-hook" mast mounting system allows for convenient mast installation and removal. A bronze phenolic mast pivot bushing with woven reinforcement offers high load carrying capability with outstanding durability.

#### **Options**

PSI 2.4L dual fuel engine  
Kubota 2.5L LPG engine  
Kubota 2.4L Tier 4 Final turbo diesel engine  
Techtronix 100 transmission  
– Auto Deceleration System  
– Controlled power reversal feature  
– Controlled rollback on ramps

Powertrain protection with engine shutdown system  
Premium monitoring package  
High air intake with precleaner Accumulator  
Keyless start (w/auxiliary key switch)  
Various light packages  
– Two brake/back-up high intensity LED lights  
– Two front and one rear halogen or LED work lights  
– Two front, one rear halogen or LED work light and two brake/tail/back-up high intensity LED lights  
Traction speed limiter  
Heavy duty anti-clog radiator  
Heavy duty combi-cooler radiator  
Swing-out, drop-down EZ-tank bracket  
Accutouch mini-lever electro-hydraulic control  
Return-to-set tilt  
Rear drive handle with horn button  
High-visibility non-cinch seat belt with or without interlock  
Polycarbonate overhead guard rain top  
Swivel full-suspension seat  
Foot Directional Control pedal  
Extension tubes with or without quick disconnects  
10° forward/6° backward tilt  
Operator password  
Load weight display  
Impact monitor  
Seatside directional control  
Integral sideshifting fork positioner  
Dual side view mirrors  
Audible alarm - reverse actuated  
82-102 db(A) self-adjusting  
Visible alarm amber strobe light - continuous activated, overhead guard mounted  
Paper applications kit  
Operator pre-shift checklist  
Oil-cooled wet disc brakes  
Pneumatic shaped solid tires  
Radial tires  
Dual drive tires  
Cab with or without air conditioning  
Dual pedal inch/brake  
Vented hood  
Overhead exhaust  
Integral sideshifter  
UL options of G, GS, D, LPS or DS



YALE MATERIALS HANDLING CORPORATION

P.O. Box 7367, Greenville, NC 27835-7367

[www.yale.com](http://www.yale.com)

Yale is a Registered Trademark and  is a Registered Copyright.  
©Yale Materials Handling Corporation 2017. All Rights Reserved.

Manufactured in our own ISO 9001 and 14001 Registered Facilities

2219-3F 8/2017 All trucks shown with optional equipment.

Truck performance may be affected by the condition of the vehicle, how it is equipped and the application. Consult your Yale® Industrial Truck Dealer if any of the information shown is critical to your application. Specifications are subject to change without notice.

This truck meets all applicable mandatory requirements of ANSI B56.1 Safety Standard for Powered Industrial Trucks at the time of manufacture. Classified by Underwriters' Laboratories, Inc., as to fire and electric shock hazard only for Type E industrial trucks.

The Yale® products included in this document may be covered by US patent 6,684,148 and other patents pending.