

GP080-120VX series

Sit-down, counterbalanced, ICE, pneumatic tire
8,000–12,000 lbs.



Delivering customer satisfaction

Yale's unique relationship with our customers is a product of our customer satisfaction commitment combined with world-class manufacturing. Yale's goal is to anticipate the needs of every customer and address them with lift trucks that deliver the performance, value and dependability our customers demand.



A leader in materials handling.

Yale has invested heavily in people, processes and capital equipment to encompass the cornerstones of quality and dependability... Innovative Design, Comprehensive Testing, Highest Quality, Advanced Components and Superior Manufacturing.

Veracity means adherence to the truth. From these origins comes the Veracitor® VX series. True to our customers. True to your application. And true to our promise of productivity. Each truck in the Veracitor® VX series of internal combustion engine lift trucks has been designed with component commonality for simplified operational maintenance, and customizable productivity packages for specific customer needs.



Designed for **comfort.**

Operator comfort is enhanced by the increased foot space in the well-designed operator's compartment. The isolated powertrain reduces noise and vibration helping to minimize operator fatigue and increasing operator productivity throughout a shift. Greater operator visibility is afforded through the Yale® Hi-Vis™ mast. Innovative designs like our optimized step height, 3-point entry, increased shoulder clearance, easy right-side access and ergonomically-designed controls make this a comfortable ride for the operator.

Optional electro-hydraulic controls

The optional Yale® Accutouch mini-lever electro-hydraulic control with on-demand load-sensing hydraulics offers an excellent ergonomic design with shorter reach and throw and considerably less effort required to operate versus common hydraulic levers. The fully-adjustable armrest is contoured for maximum comfort and flexibility to minimize muscle and joint strain.

Low step height

A low step height provides easy entry and exit. The standard, cowl-mounted manual hydraulic levers also allow easy access for right-side entry/exit. The overhead guard design offers plenty of headroom with great visibility of upper mast heights.

Optional Techtronix 100 transmission

The Auto Deceleration System (standard on the Yale® Techtronix transmissions) reduces brake pedal usage, and therefore operator leg fatigue. Controlled power reversal with automatic inching control moves loads more efficiently with less operator fatigue and product damage.

Optional rear drive handle

Rear driving comfort has been enhanced with an optional convenient rear drive handle (complete with horn button) optimally placed on the rear overhead guard leg. The rear drive handle, in conjunction with an optional swivel seat, creates a comfortable and secure work environment. A moderately-sized steering wheel, and the infinitely adjustable steer column, accommodates operators of all sizes.



Optional Accutouch mini-lever electro-hydraulic controls with on-demand hydraulics



Low step height



Optional rear drive handle with horn button



Infinitely adjustable steer column

- Designed for the operator
- High visibility
- Easy access
- Spacious cabin
- Adjustable full suspension seat



- Fast travel and mast speeds
- Enhanced controllability
- High residual lift capacities
- Optional on-demand hydraulics
- Longer uptime

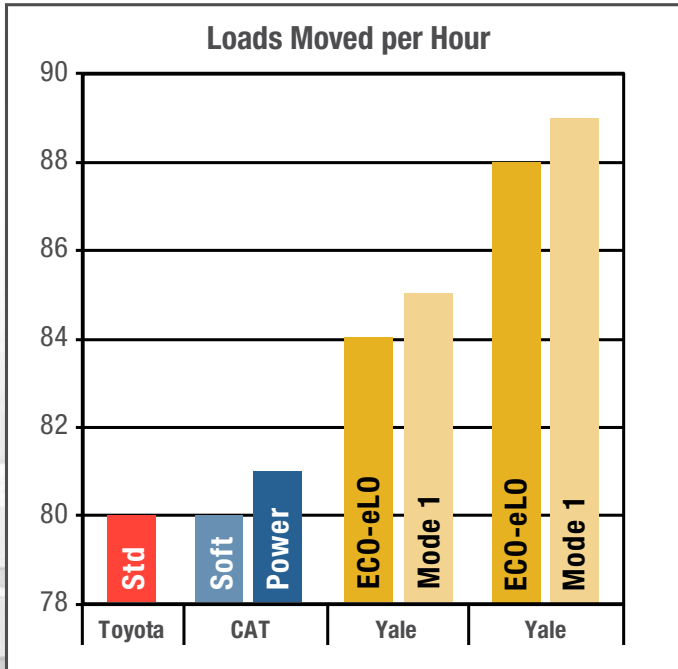

Even in standard operating mode, the Yale® GP080VX lift truck moves more loads per hour than leading competitors. The optional on-demand hydraulics boost productivity even further by allowing more engine power to be applied to the transmission rather than pumping unnecessary hydraulic oil. Both engines are tuned for the most effective performance / fuel economy balance.

(VDI Turnover Output (VDI 2198, Dec 2012, Section 7.5-7.7). Reference TEP 313.)



Ultimate productivity.

This series of trucks is available in several configurations to meet and exceed your material handling application requirements. The Veracitor® trucks can be configured for maximum performance with state-of-the-art-features and superior power. Trucks operating in standard and medium-duty requirements can be optimized for lowest cost of operation while maintaining excellent performance.

Powertrain options

The Yale Veracitor® VX series offers a variety of productivity options, featuring the PSI 4.3L V-6 engine, Kubota 3.8L LPG, Kubota 3.8L Dual Fuel or Kubota 3.8L turbo diesel engine.

Two transmission selections are available: Electronic Powershift and Techtronix 100. The Electronic Powershift features electronic shift control, electronic inching (requires no adjustment), and heavy duty clutch packs. The Techtronix 100 transmission additionally features the Auto Deceleration System—bringing the unit to a complete stop when the accelerator pedal is released, and controlled power reversals—reducing tire spin by precisely regulating engine speed. Controlled ramp descent limits roll to three inches per second. Both Electronic Powershift and Techtronix 100 transmissions are also available with two forward speeds for additional travel speed and gradeability.

Yale® Flex Performance Technology™

The innovative Yale® Flex Performance Technology™ offers the flexibility to maximize fuel economy or productivity to match application needs. The GP080-120VX series features two modes that allow customers to tailor productivity levels to the demands of their application. This feature provides operators the ability to achieve a balance of performance and superior fuel economy, or to maximize productivity during peak business periods when moving more loads is integral to the success of your operation.



PSI 4.3L V-6 LPG engine



Kubota 3.8L LPG or turbo diesel engine (LPG shown)

Low cost of operation.

- Reduces brake and tire wear
- Auto deceleration system
- On-demand hydraulics
- Kubota turbo diesel engine
- Easy to service

The purchase price of a truck is only a small part of its overall cost. A lift truck's cost of ownership is the largest portion of dollars spent and includes such elements as periodic maintenance, unscheduled repairs, tires, brakes and fuel costs. The Yale engineers focused on cost savings with additional engine and transmission options, world-class serviceability and unparalleled dependability. The Veracitor® VX truck offers substantial operating cost savings over the competition.

Reduced wear on brakes and tires

The wet disc brakes further lower the operating costs of the truck by virtually eliminating brake maintenance. Fully sealed against contamination, these brakes are ideal for tough environments, and often last the life the truck. Premium force-cooled wet disc brakes are standard on GP100-120VX models and optional on GP080-090VX models.

Techtronix transmission

The Auto Deceleration System, built into the techtronix transmission, automatically slows the truck when the throttle pedal is released, minimizing brake usage requirements and reducing associated brake wear costs. Controlled power reversal feature reduces tire spin, increasing tire life by up to 50%. This feature is programmable to match the needs from delicate to more aggressive settings for maximum productivity. The Kubota turbo diesel features a diesel oxidation catalyst (DOC) design that avoids particulate filters.

Smart hydraulics

The optional on-demand hydraulic system is load-sensing, delivering oil flow only when required, saving customers up to 20% in fuel consumption. The system consumes less fuel than a typical fixed displacement hydraulic system while producing less heat. Oil and filters last longer; hoses, seals and components also wear less and last longer. Accutouch mini-levers provide low effort, tactile control of all hydraulic functions.



Simplified serviceability

Simplified daily checks and reduced service requirements help to reduce the labor cost involved with periodic maintenance and unscheduled repairs. To further aid serviceability, the floor plate requires no tools to remove and offers complete access to the powertrain.

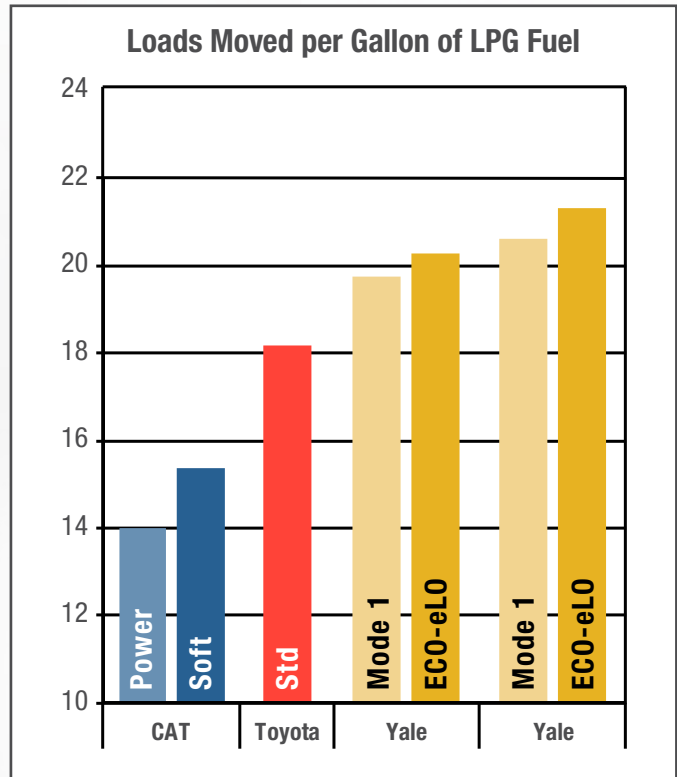

In standard performance mode, the Yale® GP080VX lift truck provides the lowest cost of operation compared to leading competitors when tested on a productivity course. The Yale® Flex Performance Technology™ option on the efficient Kubota 3.8L LPG engine allows the operator to choose which mode to use during operation: Mode 1 or ECO-eLo. The on-demand hydraulic system further reduces overall costs and greatly reduces fuel consumption by pumping hydraulic oil only when needed. Both engines are tuned for the most effective performance / fuel economy balance.

(VDI Turnover Output (VDI 2198, Dec 2012, Section 7.5-7.7). Reference TEP 313.)



Ultimate dependability.

Innovative cooling options

An optional cooling system design on the Veracitor® VX trucks enables significantly lower operating temperatures versus competitive models. The innovative system offers excellent airflow through optimized ducting and high-volume tunnels allowing our trucks to run cooler longer. Radiators are 100% shock mounted for long life. The combi-cooler radiator has a four-row aluminum core radiator and a four-row externally mounted heavy-duty transmission oil cooler for tough applications. Diesel radiators for diesel powertrains feature air to air intercoolers to increase efficiency and reduce emissions.

By keeping major components running in their optimum temperature ranges, the **optional on-demand cooling system** helps to extend the overall truck service life. The fan system is an extension of the robust hydraulic system, including superior oil filtration and O-ring face seal hydraulic fittings. By automatically reversing every 20 minutes, the hydraulically controlled cooling fan helps to keep the radiator clear of debris, reducing the need for the operator to clear it manually.

Reliable electronics

Sealed electrical connectors allow the entire truck to be pressure washed. Hall Effect sensors and switches such as the key start switch and direction shift lever have solid state components that are magnetically operated and are 100% sealed from the environment.

Intellix VSM, the smart vehicle system manager, maximizes driver efficiency by managing fast direction changes that reduce drive tire spin and tire wear. Intellix VSM maximizes uptime by monitoring and protecting key truck functions.



Optional on-demand cooling system

Continuous Stability System (CSS™)

The CSS™ reduces truck leans in turns, improving lateral stability, and the innovative steer axle mounting design allows for superior travel over uneven surfaces. Yale® CSS™ is 100% maintenance free, with no controllers, no sensors and no extra wiring. It's a reliable system that lets operators feel confident when moving loads of all shapes and sizes.



Service made simple.

Not only is the Veracitor® VX series designed to require less maintenance, it is also designed to be extremely easy to service. From the rear-opening, one-piece hood and on-board diagnostics, to the reliable, most comprehensive parts availability in the industry, these trucks were designed with service details in mind. The cowl-to-counterweight access makes servicing fast, easy and convenient, making the Veracitor® VX series the new standard in truck serviceability.

- Intellix VSM
- Reduced service costs
- On-board diagnostics
- Easily accessible components
- Parts availability program

Intellix VSM

The Intellix VSM continuously monitors truck functions and immediately alerts the operator to service needs. Extensive on-board diagnostics on the advanced dash display communicates service codes, enabling quick and accurate repairs.

Reduced service requirements

All transmissions feature smooth electronic shift control inching that requires no periodic adjustment. Controlled Techtronix power reversal feature reduces tire spin, increasing drive tire life by up to 50%. Engine coolant change and hydraulic oil change intervals are 4,000 hours. The Kubota 3.8L turbo diesel engine provides EPA certified power without the need for a diesel particulate filter. Premium wet disc brakes virtually eliminate brake maintenance and often last the life of the truck. These efficient features directly contribute to reduced service costs.

Cowl-to-counterweight access

The Veracitor® VX truck has a rear-opening, one-piece hood that opens 85 degrees. Coupled with the one-piece floor plate, excellent cowl-to-counterweight access is provided. The uncluttered layout under the hood offers clean hydraulic and electrical routings. As a result, engine compartment daily checks are all located within close reach and are easily performed.

Easy access radiator

The soft rubber, isolator mounted radiator is easy to access by removing the cover, held in place by thumbscrews. The filler cap and optional radiator lint screen can also be removed without the use of tools.

Reduce radiator cleaning frequency by choosing the optional on-demand cooling system. The hydraulic fan drive controls the speed and rotational direction of the fan. During normal operation, the default reverse feature is set to run automatically for 20 seconds every 20 minutes. For heavier duty applications, a manual dash control button allows the operator to initiate a reversal manually.

- Reduces debris vacuuming that can clog the radiator.
- Uses less power to maintain target powertrain temperatures than standard system.
- Increases fuel efficiency.
- Lowers fan speeds, reducing noise levels.



Swing-out EZ-tank (optional)

The optional swing-out, drop-down EZ-tank bracket swings out and drops down approximately 60 degrees for virtually effortless removal and installation of the LPG tank.



Supporting customers

With world-class parts and service

Our Guaranteed Availability Program (G.A.P.) ensures that parts that are normally required in the first 2 years of operation will be available from your Yale® parts dealer within 24 hours or they are free. With four Parts Distribution Centers strategically located around the world, we provide a full range of original equipment and aftermarket parts that maintain our customers' uptime.*

We also take that commitment into the field with Yale's ProTech® Certification training program, available to our dealers' technicians. The ProTech® technical training program provides both systems level as well as product specific education to ensure lift trucks are repaired right the first time.

**Consult your local dealer for G.A.P. program rules.*

GP080VX specifications

		Yale				
GENERAL	1	Manufacturer Name				
	2	Model	GP080VX			
		Engine	PSI 4.3L	Kubota 3.8L LPG		
	3	Rated Capacity	lb (kg)	8000 (3629)		
	4	Load Center, Distance	in (mm)	24 (610)		
	5	Power Type		LPG		
	6	Operator Type		Sit-Down Rider		
	7	Step Height	in (mm)	17.4 (441)		
	8	Tire Type - Cushion, Solid, Pneumatic		Pneumatic		
DIMENSIONS	9	Wheels, Number - Front/ Rear	X driven	2x/2		
	10	Lift Height, Top of Fork (TOF)	in (mm)	120 (3050)		
	11	Lift Heights, Standard Limited Free Lift (LFL) with LBR (TOF)	in (mm)	4 (100)		
		Lift Heights, Optional Full Free Lift (FFL) with LBR (TOF)	in (mm)	36 (924)		
	12	Standard Carriage Width	in (mm)	48 (1219)		
	13	Forks, Thickness x Width x Length	in (mm)	2 X 5 X 48 (50 X 125 X 1219)		
	14	Fork Spread, Outside Dimensions	in (mm)	43.5 (1106)		
	15	Mast Tilt Angles, Forward/Backward	degrees	6/10		
	16	Length To Face of Forks	in (mm)	116 (2946)		
	17	Overall Width, Standard Tread	in (mm)	55.2 (1402)		
		Overall Width, Wide Tread	in (mm)	58.5 (1485)		
	18	Height, Standard Mast - Lowered	in (mm)	86 (2171)		
	19	Height, Standard Mast - Extended with LBR	in (mm)	170 (4297)		
		Height, Standard Mast - Extended without LBR	in (mm)	151 (3815)		
20	Height, Standard Overhead Guard	in (mm)	89 (2260)			
	Height, Optional Overhead Guard	in (mm)	87 (2193)			
	Height, Overhead Guard with Operator Cab	in (mm)	90 (2281)			
21	Turning Radius, Minimum Outside (OTR)	in (mm)	101.2 (2570)			
22	Length, Center of Wheel to Face of Forks	in (mm)	20.6 (523)			
23	Aisle Width, Right Angle Stack (Add Length of Load)	in (mm)	121.8 (3093)			
24	Equal Aisle, 90-Degree Intersecting Aisle (48" L X 40" W Load)	in (mm)	90.6 (2302)			
PERFORMANCE †	25	Travel Speed RL/NL	1-Speed	mph (km/h)	12.2/12.8 (19.7/20.6)	
			2-Speed	mph (km/h)	15.7/16 (25.2/25.7)	
	26	Lift Speed, Standard 2-Stage LFL RL/NL		ft/min (m/s)	121/125 (.61/.63)	
		Lift Speed, Optional 2-Stage FFL RL/NL		ft/min (m/s)	108/111 (.54/.56)	
		Lift Speed, Optional 3-Stage FFL RL/NL		ft/min (m/s)	113/117 (.57/.59)	
	27	Lowering Speed, Standard 2-Stage LFL RL/NL		ft/min (m/s)	108/93 (.55/.47)	
		Lowering Speed, Optional 2-Stage FFL RL/NL		ft/min (m/s)	98/71 (.50/.36)	
		Lowering Speed, Optional 3-Stage FFL RL/NL		ft/min (m/s)	104/87 (.53/.44)	
	28	Max Drawbar Pull RL/NL	1-Speed	lb (kg)	5918/3406 (2685/1545)	
			2-Speed	lb (kg)	7126/3406 (3232/1545)	
		Drawbar Pull @ 1 mph RL/NL	1-Speed	lb (kg)	5077/3406 (2303/1545)	
			2-Speed	lb (kg)	6002/3406 (2722/1545)	
	29	Max Gradeability RL/NL ††	1-Speed	%	29/27	
		2-Speed	%	36/27		
	Gradeability @ 1 mph RL/NL ††	1-Speed	%	25/27		
		2-Speed	%	30/27		
WT.	31	Weight, Standard Truck (Standard 2-Stg. LFL) NL	lb (kg)	13076 (5931)	13274 (6021)	
		Weight, Standard Truck (Standard 2-Stg. LFL) RL	lb (kg)	21076 (9560)	21274 (9650)	
	32	Axle Loading, Static Front/Rear NL	lb (kg)	5677/7399 (2575/3356)	5756/7518 (2611/3410)	
		Axle Loading, Static Front/Rear RL	lb (kg)	18628/2448 (8450/1110)	18707/2567 (8485/1164)	
TIRES & WHEELS	33	Tire Size, Front		250 x 15 - 20 Ply		
	34	Tire Size, Rear		7.00 x 12 - 14 Ply		
	35	Wheelbase	in (mm)	72 (1830)		
	37	Ground Clearance, Lowest Point NL (with RL subtract -6mm)	in (mm)	5.9 (151)		
	38	Ground Clearance, Center of Wheelbase NL	in (mm)	7.6 (194)		
	39	Service Brake - Method of Control/Operation		Foot/Hydraulic		
	40	Parking Brake - Method of Control/Operation		Hand/Mechanical		
POWERTRAIN	41	Battery Type		Maintenance Free		
	42	Volts/Cold Cranking Amps	v/cca	12/475		
	43	Engine, Manufacturer/Model		PSI 4.3L V6	Kubota WG3800 LPG	
	44	Permanent Output	hp (kW)	74(55) @ 1800RPM		
	45	Torque @ Rated RPM	ft/lbs (kg/m)	210(285) @1800RPM	221(300) @1000RPM	
	46	Number of Cylinders/Displacement	No/cc (ci)	6/4302 (263)	4/3769 (230)	
		Standard Speeds, Forward/Reverse		1/1		
	49	Hydraulic Tank - capacity (drain & refill)	gal (liter)	13.5 (51.0)		
	50	Fuel Tank Capacity (Gas & Diesel Only)	gal (liter)	N/A		
	51	Auxiliary Hydraulic Pressure Relief for Attachments	PSI (Mpa)	2250 (15.5)		

Above specifications, unless otherwise listed, are for a standard truck without optional equipment.

Right Angle Stack and Equal Intersecting Aisle dimensions provided with a 48" long and 40" wide pallet load, allowing zero clearance.

RL = Rated Load, NL = No Load

GP080VX specifications

		Yale				
GENERAL	1	Manufacturer Name				
	2	Model	GP080VX			
		Engine	Kubota 3.8L Dual Fuel		Kubota 3.8L DSL	
	3	Rated Capacity	lb (kg)	8000 (3629)		
	4	Load Center, Distance	in (mm)	24 (610)		
	5	Power Type		LPG	Gasoline Diesel	
	6	Operator Type		Sit-Down Rider		
	7	Step Height	in (mm)	17.4 (441)		
	8	Tire Type - Cushion, Solid, Pneumatic		Pneumatic		
DIMENSIONS	9	Wheels, Number - Front/ Rear	X driven	2x/2		
	10	Lift Height, Top of Fork (TOF)	in (mm)	120 (3050)		
	11	Lift Heights, Standard Limited Free Lift (LFL) with LBR (TOF)	in (mm)	4 (100)		
		Lift Heights, Optional Full Free Lift (FFL) with LBR (TOF)	in (mm)	36 (924)		
	12	Standard Carriage Width	in (mm)	48 (1219)		
	13	Forks, Thickness x Width x Length	in (mm)	2 X 5 X 48 (50 X 125 X 1219)		
	14	Fork Spread, Outside Dimensions	in (mm)	43.5 (1106)		
	15	Mast Tilt Angles, Forward/Backward	degrees	6/10		
	16	Length To Face of Forks	in (mm)	116 (2946)		
	17	Overall Width, Standard Tread	in (mm)	55.2 (1402)		
		Overall Width, Wide Tread	in (mm)	58.5 (1485)		
	18	Height, Standard Mast - Lowered	in (mm)	86 (2171)		
	19	Height, Standard Mast - Extended with LBR	in (mm)	170 (4297)		
		Height, Standard Mast - Extended without LBR	in (mm)	151 (3815)		
		Height, Standard Overhead Guard	in (mm)	89 (2260)		
		Height, Optional Overhead Guard	in (mm)	87 (2193)		
		Height, Overhead Guard with Operator Cab	in (mm)	90 (2281)		
	21	Turning Radius, Minimum Outside (OTR)	in (mm)	101.2 (2570)		
	22	Length, Center of Wheel to Face of Forks	in (mm)	20.6 (523)		
	23	Aisle Width, Right Angle Stack (Add Length of Load)	in (mm)	121.8 (3093)		
	PERFORMANCE †	24	Equal Aisle, 90-Degree Intersecting Aisle (48" L X 40" W Load)	in (mm)	90.6 (2302)	
25		Travel Speed RL/NL	1-Speed	mph (km/h) 12.2/12.8 (19.7/20.6)		
			2-Speed	mph (km/h) 15.7/16 (25.2/25.7)		
26		Lift Speed, Standard 2-Stage LFL RL/NL		ft/min (m/s) 121/125 (.61/.63)		
			Lift Speed, Optional 2-Stage FFL RL/NL	ft/min (m/s) 108/111 (.54/.56)		
		Lift Speed, Optional 3-Stage FFL RL/NL	ft/min (m/s) 113/117 (.57/.59)			
27		Lowering Speed, Standard 2-Stage LFL RL/NL		ft/min (m/s) 108/93 (.55/.47)		
			Lowering Speed, Optional 2-Stage FFL RL/NL	ft/min (m/s) 98/71 (.50/.36)		
		Lowering Speed, Optional 3-Stage FFL RL/NL	ft/min (m/s) 104/87 (.53/.44)			
28		Max Drawbar Pull RL/NL	1-Speed	lb (kg) 5779/3406 (2621/1545)	5683/3406 (2578/1545)	5974/3406 (2710/1545)
			2-Speed	lb (kg) 6960/3406 (3157/1545)	6845/3406 (3105/1545)	7193/3406 (3263/1545)
		Drawbar Pull @ 1 mph RL/NL	1-Speed	lb (kg) 4963/3406 (2251/1545)	4885/3406 (2216/1545)	5122/3406 (2323/1545)
			2-Speed	lb (kg) 5871/3406 (2663/1545)	5780/3406 (2622/1545)	6054/3406 (2746/1545)
	29	Max Gradeability RL/NL ††	1-Speed	% 29/27	28/27	30/27
			2-Speed	% 35/27	34/27	36/27
	Gradeability @ 1 mph RL/NL ††	1-Speed	% 24/27	24/27	25/27	
		2-Speed	% 29/27	29/27	30/27	
WT.	31	Weight, Standard Truck (Standard 2-Stg. LFL) NL	lb (kg)	13274 (6021)		
		Weight, Standard Truck (Standard 2-Stg. LFL) RL	lb (kg)	21274 (9650)		
	32	Axle Loading, Static Front/Rear NL	lb (kg)	5756/7518 (2611/3410)		
		Axle Loading, Static Front/Rear RL	lb (kg)	18707/2567 (8485/1164)		
TIRES & WHEELS	33	Tire Size, Front		250 x 15 - 20 Ply		
	34	Tire Size, Rear		7.00 x 12 - 14 Ply		
	35	Wheelbase	in (mm)	72 (1830)		
	37	Ground Clearance, Lowest Point NL (with RL subtract -6mm)	in (mm)	5.9 (151)		
	38	Ground Clearance, Center of Wheelbase NL	in (mm)	7.6 (194)		
	39	Service Brake - Method of Control/Operation		Foot/Hydraulic		
	40	Parking Brake - Method of Control/Operation		Hand/Mechanical		
	41	Battery Type		Maintenance Free		
POWERTRAIN	42	Volts/Cold Cranking Amps	v/cca	12/475 12/900		
	43	Engine, Manufacturer/Model		Kubota 3.8L Dual Fuel Kubota V3800 T4 Final		
	44	Permanent Output	hp (kW)	69(52) @ 1800RPM	65(48) @ 1800RPM	74(55) @ 2200RPM
	45	Torque @ Rated RPM	ft/lbs (kg/m)	207(280) @1200RPM	189(256) @1400RPM	228(309) @1400RPM
	46	Number of Cylinders/Displacement	No/cc (ci)	4/3769 (230)		
		Standard Speeds, Forward/Reverse		1/1		
	49	Hydraulic Tank - capacity (drain & refill)	gal (liter)	13.5 (51.0)		
	50	Fuel Tank Capacity (Gas & Diesel Only)	gal (liter)	20.9 (79)		
	51	Auxiliary Hydraulic Pressure Relief for Attachments	PSI (Mpa)	2250 (15.5)		

† NOTE: Performance specifications / ratings are for truck equipped as described under Standard Equipment in this Specification Sheet. Performance specifications are affected by the condition of the vehicle and how it is equipped, as well as by the nature and condition of the operating area. Specifications are subject to change and the proposed application should be discussed with your authorized Yale Dealer.

†† Limited by traction. For further information on this dimension, please contact your local Yale dealer.

GP090VX specifications

		Yale			
GENERAL	1	Manufacturer Name			
	2	Model	GP090VX		
		Engine	PSI 4.3L	Kubota 3.8L LPG	
	3	Rated Capacity	lb (kg)	9000 (4090)	
	4	Load Center, Distance	in (mm)	24 (610)	
	5	Power Type		LPG	
	6	Operator Type		Sit-Down Rider	
	7	Step Height	in (mm)	17.4 (441)	
	8	Tire Type - Cushion, Solid, Pneumatic		Pneumatic	
DIMENSIONS	9	Wheels, Number - Front/ Rear	X driven	2x/2	
	10	Lift Height, Top of Fork (TOF)	in (mm)	120 (3050)	
	11	Lift Heights, Standard Limited Free Lift (LFL) with LBR (TOF)	in (mm)	4 (100)	
		Lift Heights, Optional Full Free Lift (FFL) with LBR (TOF)	in (mm)	36 (924)	
	12	Standard Carriage Width	in (mm)	48 (1219)	
	13	Forks, Thickness x Width x Length	in (mm)	2 X 5 X 48 (50 X 125 X 1219)	
	14	Fork Spread, Outside Dimensions	in (mm)	43.5 (1106)	
	15	Mast Tilt Angles, Forward/Backward	degrees	6/10	
	16	Length To Face of Forks	in (mm)	117.2 (2977)	
	17	Overall Width, Standard Tread	in (mm)	55.2 (1402)	
		Overall Width, Wide Tread	in (mm)	58.5 (1485)	
	18	Height, Standard Mast - Lowered	in (mm)	86 (2171)	
	19	Height, Standard Mast - Extended with LBR	in (mm)	170 (4297)	
		Height, Standard Mast - Extended without LBR	in (mm)	151 (3815)	
	20	Height, Standard Overhead Guard	in (mm)	89 (2260)	
		Height, Optional Overhead Guard	in (mm)	87 (2193)	
		Height, Overhead Guard with Operator Cab	in (mm)	90 (2281)	
	21	Turning Radius, Minimum Outside (OTR)	in (mm)	103.1 (2619)	
	22	Length, Center of Wheel to Face of Forks	in (mm)	20.6 (523)	
	23	Aisle Width, Right Angle Stack (Add Length of Load)	in (mm)	124.7 (3168)	
	PERFORMANCE +	24	Equal Aisle, 90-Degree Intersecting Aisle (48" L X 40" W Load)	in (mm)	91.6 (2325)
25		Travel Speed RL/NL	1-Speed	mph (km/h)	12.2/12.8 (19.6/20.6)
			2-Speed	mph (km/h)	15.6/16 (25.1/25.7)
26		Lift Speed, Standard 2-Stage LFL RL/NL	ft/min (m/s)	121/125 (.61/.63)	
		Lift Speed, Optional 2-Stage FFL RL/NL	ft/min (m/s)	108/111 (.54/.56)	
		Lift Speed, Optional 3-Stage FFL RL/NL	ft/min (m/s)	113/117 (.57/.59)	
27		Lowering Speed, Standard 2-Stage LFL RL/NL	ft/min (m/s)	108/93 (.55/.47)	
		Lowering Speed, Optional 2-Stage FFL RL/NL	ft/min (m/s)	98/71 (.50/.36)	
		Lowering Speed, Optional 3-Stage FFL RL/NL	ft/min (m/s)	104/87 (.53/.44)	
28		Max Drawbar Pull RL/NL	1-Speed	lb (kg)	5882/3348 (2668/1519)
			2-Speed	lb (kg)	7089/3348 (3216/1519)
		Drawbar Pull @ 1 mph RL/NL	1-Speed	lb (kg)	5040/3348 (2286/1519)
			2-Speed	lb (kg)	5965/3348 (2706/1519)
29		Max Gradeability RL/NL ††	1-Speed	%	27/25
	2-Speed		%	33/25	
	Gradeability @ 1 mph RL/NL ††	1-Speed	%	23/25	
		2-Speed	%	27/25	
WT.	31	Weight, Standard Truck (Standard 2-Stg. LFL) NL	lb (kg)	13920 (6314)	14118 (6404)
		Weight, Standard Truck (Standard 2-Stg. LFL) RL	lb (kg)	22920 (10396)	23118 (10486)
	32	Axle Loading, Static Front/Rear NL	lb (kg)	8341/5579 (3783/2531)	8420/5698 (3819/2585)
		Axle Loading, Static Front/Rear RL	lb (kg)	20150/2770 (9140/1256)	20229/2889 (9176/1310)
TIRES & WHEELS	33	Tire Size, Front		250 x 15 - 20 Ply	
	34	Tire Size, Rear		7.00 x 12 - 14 Ply	
	35	Wheelbase	in (mm)	72 (1830)	
	37	Ground Clearance, Lowest Point NL (with RL subtract -6mm)	in (mm)	5.9 (151)	
	38	Ground Clearance, Center of Wheelbase NL	in (mm)	7.6 (194)	
	39	Service Brake - Method of Control/Operation		Foot/Hydraulic	
	40	Parking Brake - Method of Control/Operation		Hand/Mechanical	
	41	Battery Type		Maintenance Free	
POWERTRAIN	42	Volts/Cold Cranking Amps	v/ccca	12/475	
	43	Engine, Manufacturer/Model		PSI 4.3L V6	Kubota WG3800 LPG
	44	Permanent Output	hp (kW)	74(55) @ 1800RPM	
	45	Torque @ Rated RPM	ft/lbs (kg/m)	210(285) @1800RPM	221(300) @1000RPM
	46	Number of Cylinders/Displacement	No/cc (ci)	6/4302 (263)	4/3769 (230)
		Standard Speeds, Forward/Reverse		1/1	
	49	Hydraulic Tank - capacity (drain & refill)	gal (liter)	13.5 (51.0)	
	50	Fuel Tank Capacity (Gas & Diesel Only)	gal (liter)	N/A	
	51	Auxiliary Hydraulic Pressure Relief for Attachments	PSI (Mpa)	2250 (15.5)	

Above specifications, unless otherwise listed, are for a standard truck without optional equipment.

Right Angle Stack and Equal Intersecting Aisle dimensions provided with a 48" long and 40" wide pallet load, allowing zero clearance.

RL = Rated Load, NL = No Load

GP090VX specifications

GENERAL	1	Manufacturer Name	Yale			
	2	Model	GP090VX			
		Engine	Kubota 3.8L Dual Fuel		Kubota 3.8L DSL	
	3	Rated Capacity	lb (kg)	9000 (4090)		
	4	Load Center, Distance	in (mm)	24 (610)		
	5	Power Type		LPG	Gasoline Diesel	
	6	Operator Type		Sit-Down Rider		
	7	Step Height	in (mm)	17.4 (441)		
	8	Tire Type - Cushion, Solid, Pneumatic		Pneumatic		
DIMENSIONS	9	Wheels, Number - Front/ Rear	X driven	2x/2		
	10	Lift Height, Top of Fork (TOF)	in (mm)	120 (3050)		
	11	Lift Heights, Standard Limited Free Lift (LFL) with LBR (TOF)	in (mm)	4 (100)		
		Lift Heights, Optional Full Free Lift (FFL) with LBR (TOF)	in (mm)	36 (924)		
	12	Standard Carriage Width	in (mm)	48 (1219)		
	13	Forks, Thickness x Width x Length	in (mm)	2 X 5 X 48 (50 X 125 X 1219)		
	14	Fork Spread, Outside Dimensions	in (mm)	43.5 (1106)		
	15	Mast Tilt Angles, Forward/Backward	degrees	6/10		
	16	Length To Face of Forks	in (mm)	117.2 (2977)		
	17	Overall Width, Standard Tread	in (mm)	55.2 (1402)		
		Overall Width, Wide Tread	in (mm)	58.5 (1485)		
	18	Height, Standard Mast - Lowered	in (mm)	86 (2171)		
	19	Height, Standard Mast - Extended with LBR	in (mm)	170 (4297)		
		Height, Standard Mast - Extended without LBR	in (mm)	151 (3815)		
	20	Height, Standard Overhead Guard	in (mm)	89 (2260)		
		Height, Optional Overhead Guard	in (mm)	87 (2193)		
		Height, Overhead Guard with Operator Cab	in (mm)	90 (2281)		
	21	Turning Radius, Minimum Outside (OTR)	in (mm)	103.1 (2619)		
	22	Length, Center of Wheel to Face of Forks	in (mm)	20.6 (523)		
	23	Aisle Width, Right Angle Stack (Add Length of Load)	in (mm)	124.7 (3168)		
	PERFORMANCE †	24	Equal Aisle, 90-Degree Intersecting Aisle (48" L X 40" W Load)	in (mm)	91.6 (2325)	
		25	Travel Speed RL/NL	1-Speed	mph (km/h)	
				2-Speed	mph (km/h)	
26		Lift Speed, Standard 2-Stage LFL RL/NL		ft/min (m/s)		
				ft/min (m/s)		
27		Lift Speed, Optional 2-Stage FFL RL/NL		ft/min (m/s)		
				ft/min (m/s)		
28		Lowering Speed, Standard 2-Stage LFL RL/NL		ft/min (m/s)		
				ft/min (m/s)		
29		Lowering Speed, Optional 2-Stage FFL RL/NL		ft/min (m/s)		
				ft/min (m/s)		
28		Lowering Speed, Optional 3-Stage FFL RL/NL		ft/min (m/s)		
				ft/min (m/s)		
28		Max Drawbar Pull RL/NL	1-Speed	5742/3348 (2605/1519)	5646/3348 (2561/1519)	5937/3348 (2693/1519)
	2-Speed		6923/3348 (3140/1519)	6808/3348 (3088/1519)	7156/3348 (3246/1519)	
29	Drawbar Pull @ 1 mph RL/NL	1-Speed	4926/3348 (2235/1519)	4848/3348 (2199/1519)	5085/3348 (2307/1519)	
		2-Speed	5834/3348 (2646/1519)	5744/3348 (2605/1519)	6017/3348 (2729/1519)	
29	Max Gradeability RL/NL ††	1-Speed	%	26/25	25/25	
		2-Speed	%	32/25	31/25	
29	Gradeability @ 1 mph RL/NL ††	1-Speed	%	22/25	22/25	
		2-Speed	%	26/25	26/25	
WT.	31	Weight, Standard Truck (Standard 2-Stg. LFL) NL	lb (kg)	14118 (6404)		
		Weight, Standard Truck (Standard 2-Stg. LFL) RL	lb (kg)	23118 (10486)		
	32	Axle Loading, Static Front/Rear NL	lb (kg)	8420/5698 (3819/2585)		
		Axle Loading, Static Front/Rear RL	lb (kg)	20229/2889 (9176/1310)		
TIRES & WHEELS	33	Tire Size, Front		250 x 15 - 20 Ply		
	34	Tire Size, Rear		7.00 x 12 - 14 Ply		
	35	Wheelbase	in (mm)	72 (1830)		
	37	Ground Clearance, Lowest Point NL (with RL subtract -6mm)	in (mm)	5.9 (151)		
	38	Ground Clearance, Center of Wheelbase NL	in (mm)	7.6 (194)		
	39	Service Brake - Method of Control/Operation		Foot/Hydraulic		
POWERTRAIN	40	Parking Brake - Method of Control/Operation		Hand/Mechanical		
	41	Battery Type		Maintenance Free		
	42	Volts/Cold Cranking Amps	vcca	12/475		
	43	Engine, Manufacturer/Model		Kubota 3.8L Dual Fuel		
	44	Permanent Output	hp (kW)	69(52) @ 1800RPM	65(48) @ 1800RPM	74(55) @ 2200RPM
	45	Torque @ Rated RPM	ft/lbs (kg/m)	207(280) @1200RPM	189(256) @1400RPM	228(309) @1400RPM
	46	Number of Cylinders/Displacement	No/cc (ci)	4/3769 (230)		
		Standard Speeds, Forward/Reverse		1/1		
	49	Hydraulic Tank - capacity (drain & refill)	gal (liter)	13.5 (51.0)		
	50	Fuel Tank Capacity (Gas & Diesel Only)	gal (liter)	20.9 (79)		
	51	Auxiliary Hydraulic Pressure Relief for Attachments	PSI (Mpa)	2250 (15.5)		

† NOTE: Performance specifications / ratings are for truck equipped as described under Standard Equipment in this Specification Sheet. Performance specifications are affected by the condition of the vehicle and how it is equipped, as well as by the nature and condition of the operating area. Specifications are subject to change and the proposed application should be discussed with your authorized Yale Dealer.

†† Limited by traction. For further information on this dimension, please contact your local Yale dealer.

GP080-090VX

specifications

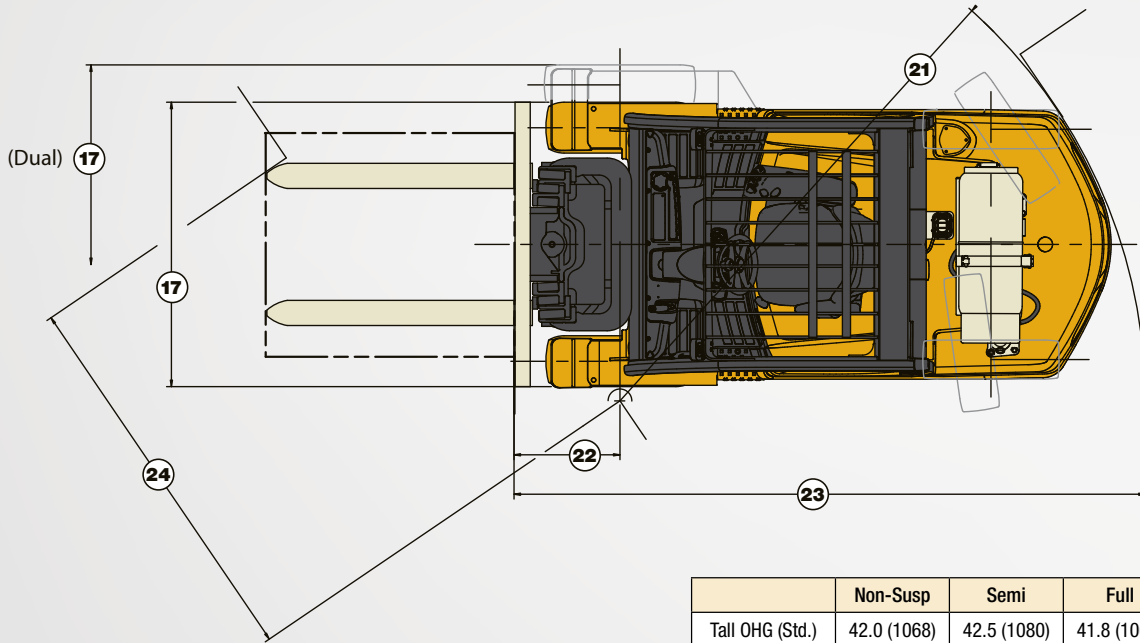

	Non-Susp	Semi	Full	Swivel Full
Tall OHG (Std.)	42.0 (1068)	42.5 (1080)	41.8 (1062)	42.0 (1068)
Short OHG (Opt.)	39.4 (1001)	39.9 (1013)	N/A	N/A

Dimensions with seat in depressed position.

TRUCK MODEL	C	D	E	T	X
	in (mm)	percent	percent	in (mm)	in (mm)
GP080VX	23.3 (593)	52%	53%	7.0 (177)	31.5 (801)
GP090VX	25.4 (645)	48%	53%	7.0 (177)	31.5 (801)

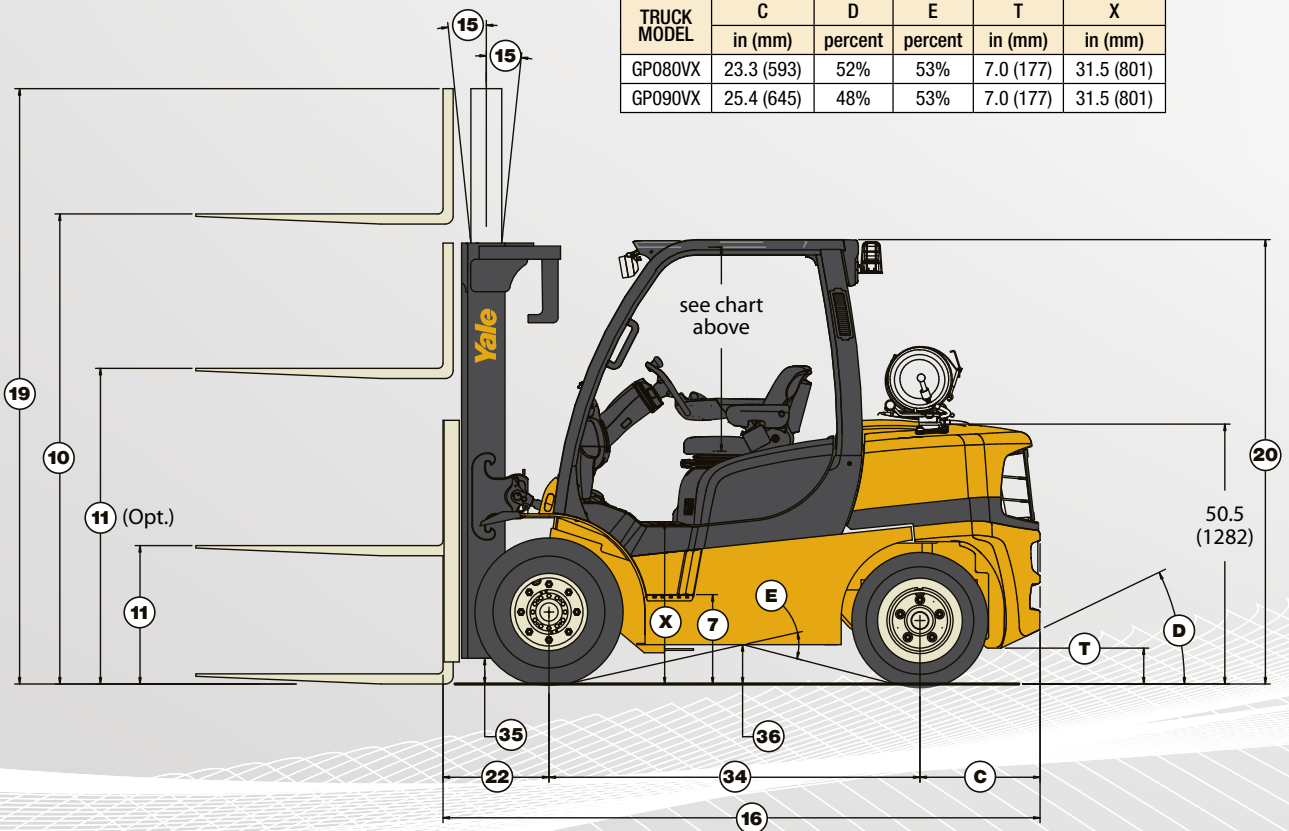

GP100-120VX

specifications

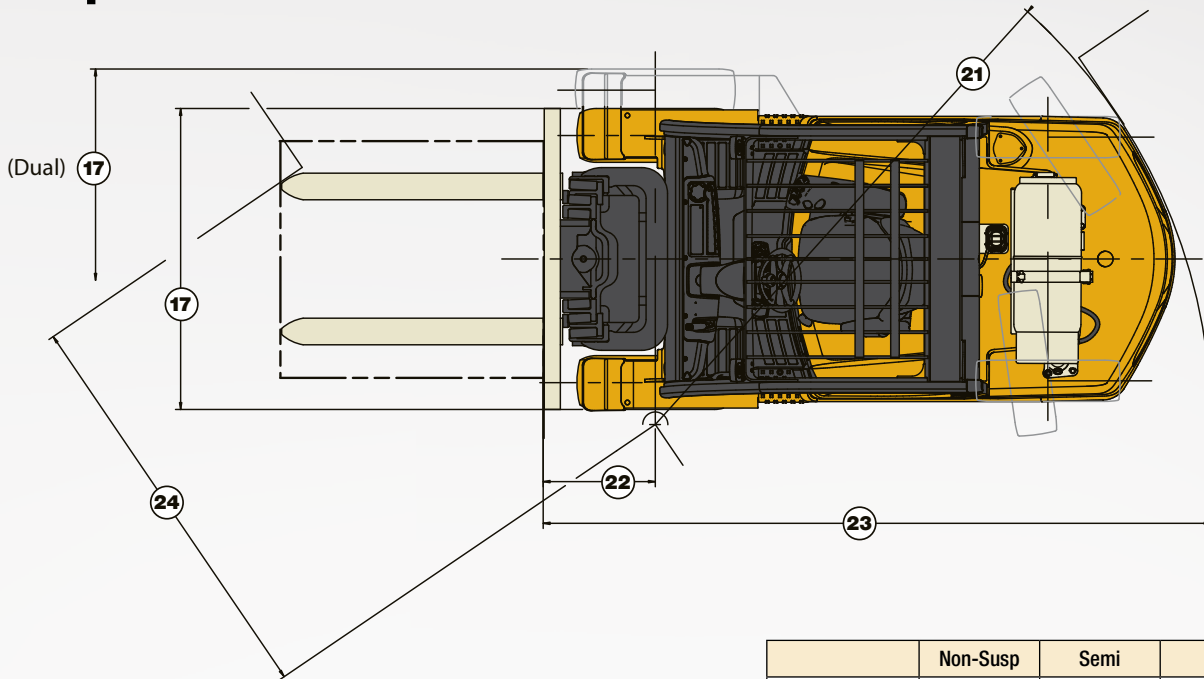

	Non-Susp	Semi	Full	Swivel Full
Tall OHG (Std.)	42.0 (1068)	42.5 (1080)	41.8 (1062)	42.0 (1068)
Short OHG (Opt.)	39.4 (1001)	39.9 (1013)	N/A	N/A

Dimensions with seat in depressed position.

TRUCK MODEL	C	D	E	T	X
	in (mm)	percent	percent	in (mm)	in (mm)
GP100VX	22.3 (566)	46%	58%	6.4 (163)	33.2 (844)
GP110VX	24.0 (609)	46%	58%	6.4 (163)	33.2 (844)
GP120VX	25.6 (650)	40%	58%	6.4 (163)	33.2 (844)

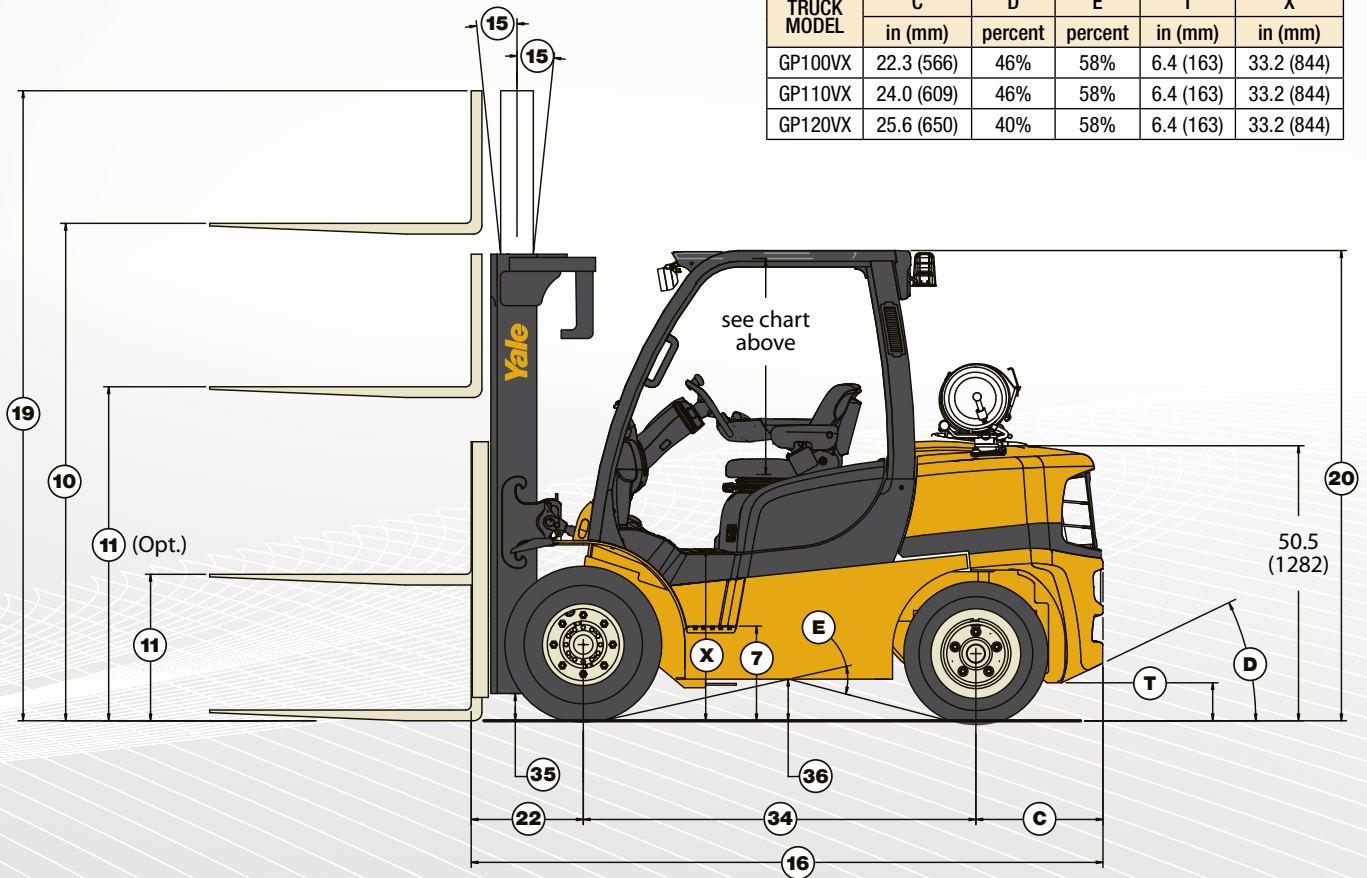

GP100VX specifications

		Yale			
GENERAL	1	Manufacturer Name			
	2	Model	GP100VX		
		Engine	PSI 4.3L	Kubota 3.8L LPG	
	3	Rated Capacity	lb (kg)	10000 (4536)	
	4	Load Center, Distance	in (mm)	24 (610)	
	5	Power Type		LPG	
	6	Operator Type		Sit-Down Rider	
	7	Step Height	in (mm)	19.1 (484)	
	8	Tire Type - Cushion, Solid, Pneumatic		Pneumatic	
DIMENSIONS	9	Wheels, Number - Front/ Rear	X driven	2x/2	
	10	Lift Height, Top of Fork (TOF)	in (mm)	109 (2790)	
	11	Lift Heights, Standard Limited Free Lift (LFL) with LBR (TOF)	in (mm)	4 (100)	
		Lift Heights, Optional Full Free Lift (FFL) with LBR (TOF)	in (mm)	37 (940)	
	12	Standard Carriage Width	in (mm)	54 (1372)	
	13	Forks, Thickness x Width x Length	in (mm)	2 X 6 X 48 (50 X 150 X 1219)	
	14	Fork Spread, Outside Dimensions	in (mm)	49.7 (1262)	
	15	Mast Tilt Angles, Forward/Backward	degrees	6/10	
	16	Length To Face of Forks	in (mm)	127.8 (3247)	
	17	Overall Width, Standard Tread	in (mm)	57.1 (1450)	
		Overall Width, Wide Tread	in (mm)	62.0 (1575)	
	18	Height, Standard Mast - Lowered	in (mm)	88 (2214)	
	19	Height, Standard Mast - Extended with LBR	in (mm)	160 (4064)	
		Height, Standard Mast - Extended without LBR	in (mm)	147 (3730)	
	20	Height, Standard Overhead Guard	in (mm)	91 (2302)	
		Height, Optional Overhead Guard	in (mm)	88 (2235)	
		Height, Overhead Guard with Operator Cab	in (mm)	92 (2323)	
	21	Turning Radius, Minimum Outside (OTR)	in (mm)	111.7 (2837)	
	22	Length, Center of Wheel to Face of Forks	in (mm)	22.9 (581)	
	23	Aisle Width, Right Angle Stack (Add Length of Load)	in (mm)	134.8 (3425)	
	PERFORMANCE +	24	Equal Aisle, 90-Degree Intersecting Aisle (48" L X 40" W Load)	in (mm)	96.6 (2452)
25		Travel Speed RL/NL	1-Speed	mph (km/h)	11.3/11.7 (18.1/18.9)
			2-Speed	mph (km/h)	14.4/14.8 (23.2/23.7)
26		Lift Speed, Standard 2-Stage LFL RL/NL	ft/min (m/s)	98/102 (.50/.51)	
		Lift Speed, Optional 2-Stage FFL RL/NL	ft/min (m/s)	92/95 (.46/.48)	
		Lift Speed, Optional 3-Stage FFL RL/NL	ft/min (m/s)	95/98 (.48/.49)	
27		Lowering Speed, Standard 2-Stage LFL RL/NL	ft/min (m/s)	100/83 (.51/.42)	
			Lowering Speed, Optional 2-Stage FFL RL/NL	ft/min (m/s)	89/63 (.45/.32)
			Lowering Speed, Optional 3-Stage FFL RL/NL	ft/min (m/s)	97/77 (.47/.39)
28		Max Drawbar Pull RL/NL	1-Speed	lb (kg)	6914/3986 (3136/1808)
			2-Speed	lb (kg)	8325/3986 (3776/1808)
		Drawbar Pull @ 1 mph RL/NL	1-Speed	lb (kg)	5809/3986 (2635/1808)
			2-Speed	lb (kg)	6834/3986 (3100/1808)
29		Max Gradeability RL/NL ††	1-Speed	%	29/28
	2-Speed		%	35/28	
	Gradeability @ 1 mph RL/NL ††	1-Speed	%	24/28	
		2-Speed	%	29/28	
WT.	31	Weight, Standard Truck (Standard 2-Stg. LFL) NL	lb (kg)	14910 (6763)	
		Weight, Standard Truck (Standard 2-Stg. LFL) RL	lb (kg)	24910 (11299)	
	32	Axle Loading, Static Front/Rear NL	lb (kg)	6642/8268 (3013/3750)	
		Axle Loading, Static Front/Rear RL	lb (kg)	22312/2598 (10121/1178)	
TIRES & WHEELS	33	Tire Size, Front		300 x 15 - 20 Ply	
	34	Tire Size, Rear		7.00 x 12 - 14 Ply	
	35	Wheelbase	in (mm)	82.7 (2100)	
	37	Ground Clearance, Lowest Point NL (with RL subtract -6mm)	in (mm)	6.4 (163)	
	38	Ground Clearance, Center of Wheelbase NL	in (mm)	9.3 (237)	
	39	Service Brake - Method of Control/Operation		Foot/Hydraulic	
	40	Parking Brake - Method of Control/Operation		Hand/Mechanical	
POWERTRAIN	41	Battery Type		Maintenance Free	
	42	Volts/Cold Cranking Amps	v/cca	12/475	
	43	Engine, Manufacturer/Model		PSI 4.3L V6	
		Permanent Output	hp (kW)	88(66) @ 2200RPM	
	45	Torque @ Rated RPM	ft/lbs (kg/m)	210(285) @2200RPM	
	46	Number of Cylinders/Displacement	No/cc (ci)	6/4302 (263)	
		Standard Speeds, Forward/Reverse		1/1	
	49	Hydraulic Tank - capacity (drain & refill)	gal (liter)	17.9 (67.8)	
	50	Fuel Tank Capacity (Gas & Diesel Only)	gal (liter)	N/A	
	51	Auxiliary Hydraulic Pressure Relief for Attachments	PSI (Mpa)	2250 (15.5)	

Above specifications, unless otherwise listed, are for a standard truck without optional equipment.

Right Angle Stack and Equal Intersecting Aisle dimensions provided with a 48" long and 40" wide pallet load, allowing zero clearance.

RL = Rated Load, NL = No Load

GP100VX specifications

		Yale				
GENERAL	1	Manufacturer Name				
	2	Model	GP100VX			
		Engine	Kubota 3.8L Dual Fuel		Kubota 3.8L DSL	
	3	Rated Capacity	lb (kg)	10000 (4536)		
	4	Load Center, Distance	in (mm)	24 (610)		
	5	Power Type		LPG	Gasoline Diesel	
	6	Operator Type		Sit-Down Rider		
	7	Step Height	in (mm)	19.1 (484)		
	8	Tire Type - Cushion, Solid, Pneumatic		Pneumatic		
DIMENSIONS	9	Wheels, Number - Front/ Rear	X driven	2x/2		
	10	Lift Height, Top of Fork (TOF)	in (mm)	109 (2790)		
	11	Lift Heights, Standard Limited Free Lift (LFL) with LBR (TOF)	in (mm)	4 (100)		
		Lift Heights, Optional Full Free Lift (FFL) with LBR (TOF)	in (mm)	37 (940)		
	12	Standard Carriage Width	in (mm)	54 (1372)		
	13	Forks, Thickness x Width x Length	in (mm)	2 X 6 X 48 (50 X 150 X 1219)		
	14	Fork Spread, Outside Dimensions	in (mm)	49.7 (1262)		
	15	Mast Tilt Angles, Forward/Backward	degrees	6/10		
	16	Length To Face of Forks	in (mm)	127.8 (3247)		
	17	Overall Width, Standard Tread	in (mm)	57.1 (1450)		
		Overall Width, Wide Tread	in (mm)	62.0 (1575)		
	18	Height, Standard Mast - Lowered	in (mm)	88 (2214)		
	19	Height, Standard Mast - Extended with LBR	in (mm)	160 (4064)		
		Height, Standard Mast - Extended without LBR	in (mm)	147 (3730)		
	20	Height, Standard Overhead Guard	in (mm)	91 (2302)		
		Height, Optional Overhead Guard	in (mm)	88 (2235)		
		Height, Overhead Guard with Operator Cab	in (mm)	92 (2323)		
	21	Turning Radius, Minimum Outside (OTR)	in (mm)	111.7 (2837)		
	22	Length, Center of Wheel to Face of Forks	in (mm)	22.9 (581)		
	23	Aisle Width, Right Angle Stack (Add Length of Load)	in (mm)	134.8 (3425)		
	PERFORMANCE †	24	Equal Aisle, 90-Degree Intersecting Aisle (48" L X 40" W Load)	in (mm)	96.6 (2452)	
		25	Travel Speed RL/NL	1-Speed	mph (km/h) 11.3/11.7 (18.1/18.9)	
				2-Speed	mph (km/h) 14.4/14.8 (23.2/23.7)	
26		Lift Speed, Standard 2-Stage LFL RL/NL		ft/min (m/s) 98/102 (.50/.51)		
			Lift Speed, Optional 2-Stage FFL RL/NL	ft/min (m/s) 92/95 (.46/.48)		
		Lift Speed, Optional 3-Stage FFL RL/NL	ft/min (m/s) 95/98 (.48/.49)			
27		Lowering Speed, Standard 2-Stage LFL RL/NL		ft/min (m/s) 100/83 (.51/.42)		
			Lowering Speed, Optional 2-Stage FFL RL/NL	ft/min (m/s) 89/63 (.45/.32)		
		Lowering Speed, Optional 3-Stage FFL RL/NL	ft/min (m/s) 97/77 (.47/.39)			
28		Max Drawbar Pull RL/NL	1-Speed	lb (kg) 6546/3986 (2969/1808)	6323/3986 (2868/1808)	6405/3986 (2905/1808)
			2-Speed	lb (kg) 7885/3986 (3577/1808)	7618/3986 (3456/1808)	7716/3986 (3500/1808)
		Drawbar Pull @ 1 mph RL/NL	1-Speed	lb (kg) 5518/3986 (2503/1808)	5341/3986 (2422/1808)	5405/3986 (2452/1808)
			2-Speed	lb (kg) 6500/3986 (2948/1808)	6297/3986 (2856/1808)	6371/3986 (2890/1808)
29		Max Gradeability RL/NL ††	1-Speed	% 27/28	26/28	27/28
			2-Speed	% 33/28	32/28	33/28
	Gradeability @ 1 mph RL/NL ††	1-Speed	% 23/28	22/28	22/28	
		2-Speed	% 27/28	26/28	26/28	
WT.	31	Weight, Standard Truck (Standard 2-Stg. LFL) NL	lb (kg)	15108 (6853)		
		Weight, Standard Truck (Standard 2-Stg. LFL) RL	lb (kg)	25108 (11389)		
	32	Axle Loading, Static Front/Rear NL	lb (kg)	6721/8387 (3049/3804)		
		Axle Loading, Static Front/Rear RL	lb (kg)	22391/2717 (10156/1232)		
TIRES & WHEELS	33	Tire Size, Front		300 x 15 - 20 Ply		
	34	Tire Size, Rear		7.00 x 12 - 14 Ply		
	35	Wheelbase	in (mm)	82.7 (2100)		
	37	Ground Clearance, Lowest Point NL (with RL subtract -6mm)	in (mm)	6.4 (163)		
	38	Ground Clearance, Center of Wheelbase NL	in (mm)	9.3 (237)		
	39	Service Brake - Method of Control/Operation		Foot/Hydraulic		
POWERTRAIN	40	Parking Brake - Method of Control/Operation		Hand/Mechanical		
	41	Battery Type		Maintenance Free		
	42	Volts/Cold Cranking Amps	v/cca	12/475 12/900		
	43	Engine, Manufacturer/Model		Kubota 3.8L Dual Fuel Kubota V3800 T4 Final		
	44	Permanent Output	hp (kW)	82(61) @ 2200RPM	78(58) @ 2200RPM	74(55) @ 2200RPM
	45	Torque @ Rated RPM	ft/lbs (kg/m)	207(280) @1200RPM	189(256) @1400RPM	228(309) @1400RPM
	46	Number of Cylinders/Displacement	No/cc (ci)	4/3769 (230)		
		Standard Speeds, Forward/Reverse		1/1		
	49	Hydraulic Tank - capacity (drain & refill)	gal (liter)	17.9 (67.8)		
	50	Fuel Tank Capacity (Gas & Diesel Only)	gal (liter)	26.5 (100.3)		
	51	Auxiliary Hydraulic Pressure Relief for Attachments	PSI (Mpa)	2250 (15.5)		

† NOTE: Performance specifications / ratings are for truck equipped as described under Standard Equipment in this Specification Sheet. Performance specifications are affected by the condition of the vehicle and how it is equipped, as well as by the nature and condition of the operating area. Specifications are subject to change and the proposed application should be discussed with your authorized Yale Dealer.
 †† Limited by traction. For further information on this dimension, please contact your local Yale dealer.

GP110VX specifications

GENERAL	1	Manufacturer Name		Yale		
	2	Model		GP110VX		
		Engine		PSI 4.3L Kubota 3.8L LPG		
	3	Rated Capacity	lb (kg)	11000 (4990)		
	4	Load Center, Distance	in (mm)	24 (610)		
	5	Power Type		LPG		
	6	Operator Type		Sit-Down Rider		
	7	Step Height	in (mm)	19.1 (484)		
	8	Tire Type - Cushion, Solid, Pneumatic		Pneumatic		
DIMENSIONS	9	Wheels, Number - Front/ Rear	X driven	2x/2		
	10	Lift Height, Top of Fork (TOF)	in (mm)	109 (2790)		
	11	Lift Heights, Standard Limited Free Lift (LFL) with LBR (TOF)	in (mm)	4 (100)		
		Lift Heights, Optional Full Free Lift (FFL) with LBR (TOF)	in (mm)	37 (940)		
	12	Standard Carriage Width	in (mm)	54 (1372)		
	13	Forks, Thickness x Width x Length	in (mm)	2 X 6 X 48 (50 X 150 X 1219)		
	14	Fork Spread, Outside Dimensions	in (mm)	49.7 (1262)		
	15	Mast Tilt Angles, Forward/Backward	degrees	6/10		
	16	Length To Face of Forks	in (mm)	129.5 (3290)		
	17	Overall Width, Standard Tread	in (mm)	57.1 (1450)		
		Overall Width, Wide Tread	in (mm)	62.0 (1575)		
	18	Height, Standard Mast - Lowered	in (mm)	88 (2214)		
	19	Height, Standard Mast - Extended with LBR	in (mm)	160 (4064)		
		Height, Standard Mast - Extended without LBR	in (mm)	147 (3730)		
	20	Height, Standard Overhead Guard	in (mm)	91 (2302)		
		Height, Optional Overhead Guard	in (mm)	88 (2235)		
		Height, Overhead Guard with Operator Cab	in (mm)	92 (2323)		
	21	Turning Radius, Minimum Outside (OTR)	in (mm)	113.3 (2877)		
	22	Length, Center of Wheel to Face of Forks	in (mm)	22.9 (581)		
	23	Aisle Width, Right Angle Stack (Add Length of Load)	in (mm)	136.4 (3465)		
	PERFORMANCE †	24	Equal Aisle, 90-Degree Intersecting Aisle (48" L X 40" W Load)	in (mm)	97.3 (2472)	
		25	Travel Speed RL/NL	1-Speed	mph (km/h)	11.2/11.7 (18.1/18.9)
				2-Speed	mph (km/h)	14.3/14.7 (23/23.7)
26		Lift Speed, Standard 2-Stage LFL RL/NL	ft/min (m/s)	98/102 (.50/.51)		
		Lift Speed, Optional 2-Stage FFL RL/NL	ft/min (m/s)	92/95 (.46/.48)		
		Lift Speed, Optional 3-Stage FFL RL/NL	ft/min (m/s)	95/98 (.48/.49)		
27		Lowering Speed, Standard 2-Stage LFL RL/NL	ft/min (m/s)	100/83 (.51/.42)		
		Lowering Speed, Optional 2-Stage FFL RL/NL	ft/min (m/s)	89/63 (.45/.32)		
		Lowering Speed, Optional 3-Stage FFL RL/NL	ft/min (m/s)	97/77 (.47/.39)		
28		Max Drawbar Pull RL/NL	1-Speed	lb (kg)	6881/3900 (3121/1769)	
			2-Speed	lb (kg)	8292/3900 (3761/1769)	
		Drawbar Pull @ 1 mph RL/NL	1-Speed	lb (kg)	5776/3900 (2620/1769)	
			2-Speed	lb (kg)	6801/3900 (3085/1769)	
29		Max Gradeability RL/NL ††	1-Speed	%	27/26	
				%	33/26	
	2-Speed		%	22/26		
			%	26/26		
WT.	31	Weight, Standard Truck (Standard 2-Stg. LFL) NL	lb (kg)	15560 (7058)		
		Weight, Standard Truck (Standard 2-Stg. LFL) RL	lb (kg)	26560 (12047)		
	32	Axle Loading, Static Front/Rear NL	lb (kg)	6499/9061 (2948/4110)		
		Axle Loading, Static Front/Rear RL	lb (kg)	23735/2825 (10766/1281)		
TIRES & WHEELS	33	Tire Size, Front		300 x 15 - 20 Ply		
	34	Tire Size, Rear		7.00 x 12 - 14 Ply		
	35	Wheelbase	in (mm)	82.7 (2100)		
	37	Ground Clearance, Lowest Point NL (with RL subtract -6mm)	in (mm)	6.4 (163)		
	38	Ground Clearance, Center of Wheelbase NL	in (mm)	9.3 (237)		
POWERTRAIN	39	Service Brake - Method of Control/Operation		Foot/Hydraulic		
	40	Parking Brake - Method of Control/Operation		Hand/Mechanical		
	41	Battery Type		Maintenance Free		
	42	Volts/Cold Cranking Amps	vcca	12/475		
	43	Engine, Manufacturer/Model		PSI 4.3L V6 Kubota WG3800 LPG		
	44	Permanent Output	hp (kW)	88(66) @ 2200RPM 86(64) @ 2200RPM		
	45	Torque @ Rated RPM	ft/lbs (kg/m)	210(285) @2200RPM 221(300) @1000RPM		
	46	Number of Cylinders/Displacement	No/cc (ci)	6/4302 (263) 4/3769 (230)		
		Standard Speeds, Forward/Reverse		1/1		
	49	Hydraulic Tank - capacity (drain & refill)	gal (liter)	17.9 (67.8)		
50	Fuel Tank Capacity (Gas & Diesel Only)	gal (liter)	N/A			
51	Auxiliary Hydraulic Pressure Relief for Attachments	PSI (Mpa)	2250 (15.5)			

Above specifications, unless otherwise listed, are for a standard truck without optional equipment.

Right Angle Stack and Equal Intersecting Aisle dimensions provided with a 48" long and 40" wide pallet load, allowing zero clearance.

RL = Rated Load, NL = No Load

GP110VX specifications

GENERAL	1	Manufacturer Name	Yale			
	2	Model	GP110VX			
		Engine	Kubota 3.8L Dual Fuel		Kubota 3.8L DSL	
	3	Rated Capacity	lb (kg)	11000 (4990)		
	4	Load Center, Distance	in (mm)	24 (610)		
	5	Power Type		LPG	Gasoline Diesel	
	6	Operator Type		Sit-Down Rider		
	7	Step Height	in (mm)	19.1 (484)		
	8	Tire Type - Cushion, Solid, Pneumatic		Pneumatic		
DIMENSIONS	9	Wheels, Number - Front/ Rear	X driven	2x/2		
	10	Lift Height, Top of Fork (TOF)	in (mm)	109 (2790)		
	11	Lift Heights, Standard Limited Free Lift (LFL) with LBR (TOF)	in (mm)	4 (100)		
		Lift Heights, Optional Full Free Lift (FFL) with LBR (TOF)	in (mm)	37 (940)		
	12	Standard Carriage Width	in (mm)	54 (1372)		
	13	Forks, Thickness x Width x Length	in (mm)	2 X 6 X 48 (50 X 150 X 1219)		
	14	Fork Spread, Outside Dimensions	in (mm)	49.7 (1262)		
	15	Mast Tilt Angles, Forward/Backward	degrees	6/10		
	16	Length To Face of Forks	in (mm)	129.5 (3290)		
	17	Overall Width, Standard Tread	in (mm)	57.1 (1450)		
		Overall Width, Wide Tread	in (mm)	62.0 (1575)		
	18	Height, Standard Mast - Lowered	in (mm)	88 (2214)		
	19	Height, Standard Mast - Extended with LBR	in (mm)	160 (4064)		
		Height, Standard Mast - Extended without LBR	in (mm)	147 (3730)		
	20	Height, Standard Overhead Guard	in (mm)	91 (2302)		
		Height, Optional Overhead Guard	in (mm)	88 (2235)		
		Height, Overhead Guard with Operator Cab	in (mm)	92 (2323)		
	21	Turning Radius, Minimum Outside (OTR)	in (mm)	113.3 (2877)		
	22	Length, Center of Wheel to Face of Forks	in (mm)	22.9 (581)		
	23	Aisle Width, Right Angle Stack (Add Length of Load)	in (mm)	136.4 (3465)		
	PERFORMANCE †	24	Equal Aisle, 90-Degree Intersecting Aisle (48" L X 40" W Load)	in (mm)	97.3 (2472)	
25		Travel Speed RL/NL	1-Speed	mph (km/h) 11.2/11.7 (18.1/18.9)		
			2-Speed	mph (km/h) 14.3/14.7 (23/23.7)		
26		Lift Speed, Standard 2-Stage LFL RL/NL	ft/min (m/s)	98/102 (.50/.51)		
		Lift Speed, Optional 2-Stage FFL RL/NL	ft/min (m/s)	92/95 (.46/.48)		
		Lift Speed, Optional 3-Stage FFL RL/NL	ft/min (m/s)	95/98 (.48/.49)		
27		Lowering Speed, Standard 2-Stage LFL RL/NL	ft/min (m/s)	100/83 (.51/.42)		
		Lowering Speed, Optional 2-Stage FFL RL/NL	ft/min (m/s)	89/63 (.45/.32)		
		Lowering Speed, Optional 3-Stage FFL RL/NL	ft/min (m/s)	97/77 (.47/.39)		
28		Max Drawbar Pull RL/NL	1-Speed	lb (kg) 6513/3900 (2954/1769)	6290/3900 (2853/1769)	6372/3900 (2890/1769)
			2-Speed	lb (kg) 7852/3900 (3562/1769)	7585/3900 (3441/1769)	7683/3900 (3485/1769)
		Drawbar Pull @ 1 mph RL/NL	1-Speed	lb (kg) 5485/3900 (2488/1769)	5308/3900 (2408/1769)	5372/3900 (2437/1769)
			2-Speed	lb (kg) 6467/3900 (2933/1769)	6264/3900 (2841/1769)	6338/3900 (2875/1769)
29		Max Gradeability RL/NL ††	1-Speed	% 25/26	24/26	25/26
	2-Speed		% 31/26	30/26	30/26	
	Gradeability @ 1 mph RL/NL ††	1-Speed	% 21/26	20/26	21/26	
		2-Speed	% 25/26	24/26	25/26	
WT.	31	Weight, Standard Truck (Standard 2-Stg. LFL) NL	lb (kg)	15758 (7148)		
		Weight, Standard Truck (Standard 2-Stg. LFL) RL	lb (kg)	26758 (12137)		
	32	Axle Loading, Static Front/Rear NL	lb (kg)	6578/9180 (2984/4164)		
		Axle Loading, Static Front/Rear RL	lb (kg)	23814/2944 (10802/1335)		
TIRES & WHEELS	33	Tire Size, Front		300 x 15 - 20 Ply		
	34	Tire Size, Rear		7.00 x 12 - 14 Ply		
	35	Wheelbase	in (mm)	82.7 (2100)		
	37	Ground Clearance, Lowest Point NL (with RL subtract -6mm)	in (mm)	6.4 (163)		
	38	Ground Clearance, Center of Wheelbase NL	in (mm)	9.3 (237)		
	39	Service Brake - Method of Control/Operation		Foot/Hydraulic		
	40	Parking Brake - Method of Control/Operation		Hand/Mechanical		
	41	Battery Type		Maintenance Free		
POWERTRAIN	42	Volts/Cold Cranking Amps	vcca	12/475 12/900		
	43	Engine, Manufacturer/Model		Kubota 3.8L Dual Fuel Kubota V3800 T4 Final		
	44	Permanent Output	hp (kW)	82(61) @ 2200RPM	78(58) @ 2200RPM	74(55) @ 2200RPM
	45	Torque @ Rated RPM	ft/lbs (kg/m)	207(280) @1200RPM	189(256) @1400RPM	228(309) @1400RPM
	46	Number of Cylinders/Displacement	No/cc (ci)	4/3769 (230)		
		Standard Speeds, Forward/Reverse		1/1		
	49	Hydraulic Tank - capacity (drain & refill)	gal (liter)	17.9 (67.8)		
	50	Fuel Tank Capacity (Gas & Diesel Only)	gal (liter)	26.5 (100.3)		
	51	Auxiliary Hydraulic Pressure Relief for Attachments	PSI (Mpa)	2250 (15.5)		

† NOTE: Performance specifications / ratings are for truck equipped as described under Standard Equipment in this Specification Sheet. Performance specifications are affected by the condition of the vehicle and how it is equipped, as well as by the nature and condition of the operating area. Specifications are subject to change and the proposed application should be discussed with your authorized Yale Dealer.

†† Limited by traction. For further information on this dimension, please contact your local Yale dealer.

GP120VX specifications

		Yale	
GENERAL	1	Manufacturer Name	Yale
	2	Model	GP120VX
		Engine	PSI 4.3L Kubota 3.8L LPG
	3	Rated Capacity	lb (kg) 12000 (5443)
	4	Load Center, Distance	in (mm) 24 (610)
	5	Power Type	LPG
	6	Operator Type	Sit-Down Rider
	7	Step Height	in (mm) 19.1 (484)
	8	Tire Type - Cushion, Solid, Pneumatic	Pneumatic
DIMENSIONS	9	Wheels, Number - Front/ Rear	X driven 2x/2
	10	Lift Height, Top of Fork (TOF)	in (mm) 110 (2800)
	11	Lift Heights, Standard Limited Free Lift (LFL) with LBR (TOF)	in (mm) 4 (100)
		Lift Heights, Optional Full Free Lift (FFL) with LBR (TOF)	in (mm) 37 (940)
	12	Standard Carriage Width	in (mm) 54 (1372)
	13	Forks, Thickness x Width x Length	in (mm) 2 X 6 X 48 (50 X 150 X 1219)
	14	Fork Spread, Outside Dimensions	in (mm) 49.7 (1262)
	15	Mast Tilt Angles, Forward/Backward	degrees 6/10
	16	Length To Face of Forks	in (mm) 131.5 (3341)
	17	Overall Width, Standard Tread	in (mm) 57.1 (1450)
		Overall Width, Wide Tread	in (mm) 62.0 (1575)
	18	Height, Standard Mast - Lowered	in (mm) 88 (2214)
	19	Height, Standard Mast - Extended with LBR	in (mm) 160 (4064)
		Height, Standard Mast - Extended without LBR	in (mm) 147 (3730)
	20	Height, Standard Overhead Guard	in (mm) 91 (2302)
		Height, Optional Overhead Guard	in (mm) 88 (2235)
		Height, Overhead Guard with Operator Cab	in (mm) 92 (2323)
	21	Turning Radius, Minimum Outside (OTR)	in (mm) 114.8 (2915)
	22	Length, Center of Wheel to Face of Forks	in (mm) 22.9 (591)
	23	Aisle Width, Right Angle Stack (Add Length of Load)	in (mm) 137.9 (3503)
	PERFORMANCE †	24	Equal Aisle, 90-Degree Intersecting Aisle (48" L X 40" W Load)
25		Travel Speed RL/NL 1-Speed	mph (km/h) 11.2/11.7 (18/18.8)
		2-Speed	mph (km/h) 14.2/14.7 (22.9/23.7)
26		Lift Speed, Standard 2-Stage LFL RL/NL	ft/min (m/s) 98/102 (.50/.51)
		Lift Speed, Optional 2-Stage FFL RL/NL	ft/min (m/s) 92/95 (.46/.48)
		Lift Speed, Optional 3-Stage FFL RL/NL	ft/min (m/s) 95/98 (.48/.49)
27		Lowering Speed, Standard 2-Stage LFL RL/NL	ft/min (m/s) 100/83 (.51/.42)
		Lowering Speed, Optional 2-Stage FFL RL/NL	ft/min (m/s) 89/63 (.45/.32)
		Lowering Speed, Optional 3-Stage FFL RL/NL	ft/min (m/s) 97/77 (.47/.39)
28		Max Drawbar Pull RL/NL 1-Speed	lb (kg) 6846/3904 (3105/1771)
		2-Speed	lb (kg) 8257/3904 (3745/1771)
29		Drawbar Pull @ 1 mph RL/NL 1-Speed	lb (kg) 5741/3904 (2604/1771)
		2-Speed	lb (kg) 6766/3904 (3069/1771)
29		Max Gradeability RL/NL †† 1-Speed	% 25/25
	2-Speed	% 30/25	
	Gradeability @ 1 mph RL/NL †† 1-Speed	% 23/25	
	2-Speed	% 20/26	
WT.	31	Weight, Standard Truck (Standard 2-Stg. LFL) NL	lb (kg) 16321 (7403)
		Weight, Standard Truck (Standard 2-Stg. LFL) RL	lb (kg) 28321 (12846)
	32	Axle Loading, Static Front/Rear NL	lb (kg) 6505/9816 (2951/4452)
		Axle Loading, Static Front/Rear RL	lb (kg) 25366/2955 (11506/1340)
TIRES & WHEELS	33	Tire Size, Front	300 x 15 - 20 Ply
	34	Tire Size, Rear	7.00 x 12 - 14 Ply
	35	Wheelbase	in (mm) 82.7 (2100)
	37	Ground Clearance, Lowest Point NL (with RL subtract -6mm)	in (mm) 6.4 (163)
	38	Ground Clearance, Center of Wheelbase NL	in (mm) 9.3 (237)
	39	Service Brake - Method of Control/Operation	Foot/Hydraulic
POWERTRAIN	40	Parking Brake - Method of Control/Operation	Hand/Mechanical
	41	Battery Type	Maintenance Free
	42	Volts/Cold Cranking Amps	vcca 12/475
	43	Engine, Manufacturer/Model	PSI 4.3L V6 Kubota WG3800 LPG
	44	Permanent Output	hp (kW) 88(66) @ 2200RPM 86(64) @ 2200RPM
	45	Torque @ Rated RPM	ft/lbs (kg/m) 210(285) @2200RPM 221(300) @1000RPM
	46	Number of Cylinders/Displacement	No/cc (ci) 6/4302 (263) 4/3769 (230)
		Standard Speeds, Forward/Reverse	1/1
	49	Hydraulic Tank - capacity (drain & refill)	gal (liter) 17.9 (67.8)
	50	Fuel Tank Capacity (Gas & Diesel Only)	gal (liter) N/A
	51	Auxiliary Hydraulic Pressure Relief for Attachments	PSI (Mpa) 2250 (15.5)

Above specifications, unless otherwise listed, are for a standard truck without optional equipment.

Right Angle Stack and Equal Intersecting Aisle dimensions provided with a 48" long and 40" wide pallet load, allowing zero clearance.

RL = Rated Load, NL = No Load

GP120VX specifications

GENERAL	1	Manufacturer Name	Yale			
	2	Model	GP120VX			
		Engine	Kubota 3.8L Dual Fuel		Kubota 3.8L DSL	
	3	Rated Capacity	lb (kg)	12000 (5443)		
	4	Load Center, Distance	in (mm)	24 (610)		
	5	Power Type		LPG	Gasoline	Diesel
	6	Operator Type	Sit-Down Rider			
	7	Step Height	in (mm)	19.1 (484)		
	8	Tire Type - Cushion, Solid, Pneumatic	Pneumatic			
DIMENSIONS	9	Wheels, Number - Front/ Rear	X driven	2x/2		
	10	Lift Height, Top of Fork (TOF)	in (mm)	110 (2800)		
	11	Lift Heights, Standard Limited Free Lift (LFL) with LBR (TOF)	in (mm)	4 (100)		
		Lift Heights, Optional Full Free Lift (FFL) with LBR (TOF)	in (mm)	37 (940)		
	12	Standard Carriage Width	in (mm)	54 (1372)		
	13	Forks, Thickness x Width x Length	in (mm)	2 X 6 X 48 (50 X 150 X 1219)		
	14	Fork Spread, Outside Dimensions	in (mm)	49.7 (1262)		
	15	Mast Tilt Angles, Forward/Backward	degrees	6/10		
	16	Length To Face of Forks	in (mm)	131.5 (3341)		
	17	Overall Width, Standard Tread	in (mm)	57.1 (1450)		
		Overall Width, Wide Tread	in (mm)	62.0 (1575)		
	18	Height, Standard Mast - Lowered	in (mm)	88 (2214)		
	19	Height, Standard Mast - Extended with LBR	in (mm)	160 (4064)		
		Height, Standard Mast - Extended without LBR	in (mm)	147 (3730)		
	20	Height, Standard Overhead Guard	in (mm)	91 (2302)		
		Height, Optional Overhead Guard	in (mm)	88 (2235)		
		Height, Overhead Guard with Operator Cab	in (mm)	92 (2323)		
	21	Turning Radius, Minimum Outside (OTR)	in (mm)	114.8 (2915)		
	22	Length, Center of Wheel to Face of Forks	in (mm)	22.9 (591)		
	23	Aisle Width, Right Angle Stack (Add Length of Load)	in (mm)	137.9 (3503)		
	PERFORMANCE †	24	Equal Aisle, 90-Degree Intersecting Aisle (48" L X 40" W Load)	in (mm)	98.1 (2490)	
25		Travel Speed RL/NL	1-Speed	mph (km/h) 11.2/11.7 (18/18.8)		
			2-Speed	mph (km/h) 14.2/14.7 (22.9/23.7)		
26		Lift Speed, Standard 2-Stage LFL RL/NL	ft/min (m/s)	98/102 (.50/.51)		
		Lift Speed, Optional 2-Stage FFL RL/NL	ft/min (m/s)	92/95 (.46/.48)		
		Lift Speed, Optional 3-Stage FFL RL/NL	ft/min (m/s)	95/98 (.48/.49)		
27		Lowering Speed, Standard 2-Stage LFL RL/NL	ft/min (m/s)	100/83 (.51/.42)		
		Lowering Speed, Optional 2-Stage FFL RL/NL	ft/min (m/s)	89/63 (.45/.32)		
		Lowering Speed, Optional 3-Stage FFL RL/NL	ft/min (m/s)	97/77 (.47/.39)		
28		Max Drawbar Pull RL/NL	1-Speed	lb (kg) 6478/3904 (2938/1771)	6255/3904 (2837/1771)	6336/3904 (2874/1771)
			2-Speed	lb (kg) 7817/3904 (3546/1771)	7550/3904 (3425/1771)	7647/3904 (3469/1771)
		Drawbar Pull @ 1 mph RL/NL	1-Speed	lb (kg) 5449/3904 (2472/1771)	5272/3904 (2392/1771)	5337/3904 (2421/1771)
			2-Speed	lb (kg) 6432/3904 (2917/1771)	6229/3904 (2825/1771)	6303/3904 (2859/1771)
29		Max Gradeability RL/NL ††	1-Speed	% 23/25	23/25	23/25
	2-Speed		% 29/25	28/25	28/25	
	Gradeability @ 1 mph RL/NL ††	1-Speed	% 22/28	24/28	24/28	
		2-Speed	% 22/26	22/26	21/26	
WT.	31	Weight, Standard Truck (Standard 2-Stg. LFL) NL	lb (kg)	16519 (7493)		
		Weight, Standard Truck (Standard 2-Stg. LFL) RL	lb (kg)	28519 (12936)		
	32	Axle Loading, Static Front/Rear NL	lb (kg)	6584/9935 (2986/4506)		
		Axle Loading, Static Front/Rear RL	lb (kg)	25445/3074 (11542/1394)		
TIRES & WHEELS	33	Tire Size, Front	300 x 15 - 20 Ply			
	34	Tire Size, Rear	7.00 x 12 - 14 Ply			
	35	Wheelbase	in (mm)	82.7 (2100)		
	37	Ground Clearance, Lowest Point NL (with RL subtract -6mm)	in (mm)	6.4 (163)		
	38	Ground Clearance, Center of Wheelbase NL	in (mm)	9.3 (237)		
	39	Service Brake - Method of Control/Operation	Foot/Hydraulic			
40	Parking Brake - Method of Control/Operation	Hand/Mechanical				
POWERTRAIN	41	Battery Type	Maintenance Free			
	42	Volts/Cold Cranking Amps	vcca	12/475	12/900	
	43	Engine, Manufacturer/Model	Kubota 3.8L Dual Fuel			
	44	Permanent Output	hp (kW)	82(61) @ 2200RPM	78(58) @ 2200RPM	74(55) @ 2200RPM
	45	Torque @ Rated RPM	ft/lbs (kg/m)	207(280) @1200RPM	189(256) @1400RPM	228(309) @1400RPM
	46	Number of Cylinders/Displacement	No/cc (ci)	4/3769 (230)		
		Standard Speeds, Forward/Reverse	1/1			
	49	Hydraulic Tank - capacity (drain & refill)	gal (liter)	17.9 (67.8)		
	50	Fuel Tank Capacity (Gas & Diesel Only)	gal (liter)	26.5 (100.3)		
	51	Auxiliary Hydraulic Pressure Relief for Attachments	PSI (Mpa)	2250 (15.5)		

† NOTE: Performance specifications / ratings are for truck equipped as described under Standard Equipment in this Specification Sheet. Performance specifications are affected by the condition of the vehicle and how it is equipped, as well as by the nature and condition of the operating area. Specifications are subject to change and the proposed application should be discussed with your authorized Yale Dealer.

†† Limited by traction. For further information on this dimension, please contact your local Yale dealer.

Standard equipment

- PSI 4.3L, V-6 emissions compliant engine
- One-speed powershift transmission (standard with H80-90FT)
 - Electronic inching
 - Electronic shift control
- Oil-cooled wet disc brakes
- MONOTROL® pedal
- 2-Stage limited free-lift (LFL) VISTA™ mast with maximum fork height of 120" (3050 mm) (H80-90FT) or 110" (2800 mm) (H100-120FT)
- 48" (1219 mm) (H80-90FT) or 54" (1372 mm) (H100-120FT) wide hook-type carriage with 48.0" (1219) tall load backrest
- 48" (1219 mm) long forks
- 6 degrees forward and 10 degrees backward mast tilt
- 3-function hydraulic control valve
- Integrated dashboard display includes:
 - LCD display:
 - Fuel level (gasoline or diesel only)
 - Hour meter
 - Coolant temperature
 - Clock
 - Messages
 - Service indicator lights:
 - Alternator
 - Transmission oil temperature
 - Engine oil pressure
 - Brake fluid level

Options

- Kubota 3.8L Tier 4 Final DOC turbo diesel engine
- Kubota 3.8L LPG engine
- Kubota 3.8L Dual Fuel engine
- Powertrain protection system
- Premium monitoring
- High air intake with precleaner
- Accutouch mini-lever, electro-hydraulic control with on-demand hydraulic system
- On-demand cooling system
- Full venting package
- Accumulator
- Keyless start (w/auxiliary key switch)
- LED brake and back-up lights
- Halogen or LED headlights & rear drive lights
- Traction speed limiter
- Swing-out, drop-down EZ-Tank Bracket
- Return-to-set tilt
- Rear drive handle with horn button
- Optical sensing low LPG fuel sensor
- Full-suspension, semi-suspension, or swivel full suspension seat (vinyl or cloth)
- High-visibility non-cinch seat belt with or without interlock
- Foot Directional Control pedal
- Operator password
- Mirrors – dual side view
- Alarm-reverse actuated 82-102 dB(A) – self adjusting
- Amber strobe light – continuous activated
- Paper applications kit
- 4 function (2 aux) hydraulic control valve
- 12° forward/6° backward tilt

Capacity Specific Options

GP080-090VX

- Techtronix transmission
 - Auto deceleration system
 - Controlled power reversal feature
 - Controlled roll back on ramps
- Optional Techtronix two-speed transmission
 - Additional forward speed
 - Higher gradeability and drawbar pull performance
 - Increased travel speeds
- Premium wet disc brakes

GP100-120VX

- Techtronix 100X transmission
 - Auto deceleration system
 - Controlled power reversal feature
 - Controlled roll back on ramps

GP080-090VX MAST DIMENSIONS					
Maximum Fork Height (TOF)	Overall Lowered Height	Overall Extended Height		Free-Lift (TOF)	
		w/ Load Backrest	w/o Load Backrest	w/ Load Backrest	w/o Load Backrest
in (mm)	in (mm)	in (mm)	in (mm)	in (mm)	in (mm)
2-Stage Limited Free-Lift (LFL) Mast					
120 (3050)	86 (2171)	170 (4297)	151 (3815)	5 (150)	5 (150)
143 (3650)	98 (2471)	193 (4897)	174 (4415)	5 (150)	5 (150)
167 (4250)	110 (2771)	217 (5497)	198 (5015)	5 (150)	5 (150)
2-Stage Full Free-Lift (FFL) Mast					
121 (3075)	86 (2171)	171 (4322)	154 (3887)	36 (924)	53 (1359)
144 (3675)	98 (2471)	194 (4922)	177 (4487)	48 (1224)	65 (1659)
3-Stage Full Free-Lift (FFL) Mast					
173 (4415)	86 (2171)	223 (5662)	206 (5227)	36 (924)	53 (1359)
185 (4715)	90 (2271)	235 (5962)	218 (5527)	40 (1024)	57 (1459)
194 (4950)	94 (2371)	244 (6197)	227 (5762)	44 (1124)	61 (1559)
206 (5250)	98 (2471)	256 (6497)	239 (6062)	48 (1224)	65 (1659)
218 (5550)	102 (2571)	268 (6797)	251 (6362)	52 (1324)	69 (1759)

Note: GP080-090VX has standard 250 x 15-20 PR drive tires @ 55.2 inch (1402 mm) overall width.

GP100-120VX MAST DIMENSIONS					
Maximum Fork Height (TOF)	Overall Lowered Height	Overall Extended Height		Free-Lift (TOF)	
		w/ Load Backrest	w/o Load Backrest	w/ Load Backrest	w/o Load Backrest
in (mm)	in (mm)	in (mm)	in (mm)	in (mm)	in (mm)
2-Stage Limited Free-Lift (LFL) Mast					
110 (2800)	88 (2214)	160 (4064)	147 (3730)	6 (160)	6 (160)
133 (3400)	99 (2514)	184 (4664)	171 (4330)	6 (160)	6 (160)
157 (4000)	111 (2814)	208 (5264)	195 (4930)	6 (160)	6 (160)
2-Stage Full Free-Lift (FFL) Mast					
134 (3425)	99 (2514)	185 (4689)	174 (4407)	49 (1250)	60 (1532)
3-Stage Full Free-Lift (FFL) Mast					
163 (4147)	88 (2214)	214 (5411)	202 (5129)	37 (950)	48 (1232)
175 (4447)	92 (2314)	225 (5711)	214 (5429)	41 (1050)	52 (1332)
185 (4700)	96 (2414)	235 (5964)	224 (5682)	45 (1150)	56 (1432)
196 (5000)	99 (2514)	247 (6264)	236 (5982)	49 (1250)	60 (1532)
208 (5300)	103 (2614)	259 (6564)	248 (6282)	53 (1350)	64 (1632)

Note: GP100-120VX has standard 300 x 15 drive tires @ 57.1 inch (1450 mm) overall width.

For more information, or to find your nearest Yale® dealer, go to Yale.com.



YALE MATERIALS HANDLING CORPORATION

P.O. Box 7367, Greenville, NC 27835-7367

www.yale.com

YALE,  and PEOPLE. PRODUCTS. PRODUCTIVITY. are trademarks, service marks or registered marks in the United States and certain other jurisdictions. © Yale Materials Handling Corporation 2017. All Rights Reserved.

Truck performance may be affected by the condition of the vehicle, how it is equipped and the application. Consult your Yale® Industrial Truck Dealer if any of the information shown is critical to your application.

Specifications are subject to change without notice. This truck meets all applicable mandatory requirements of ANSI B56.1 Safety Standard for Powered Industrial Trucks at the time of manufacture.

Classified by Underwriters' Laboratories, Inc., as to fire and electric shock hazard only for Type E industrial trucks.

Manufactured in our own ISO 9001 and 14001 Registered Facilities

2251J 10/2017 All trucks shown with optional equipment.