

VX Series

Diesel Forklift Trucks

17,000 / 17,500 / 19,000 lbs.

- Low cost of operation is derived from increased uptime, low maintenance and high productivity
- Designed for dependability in the most rigorous applications
- For use in high speed, high load, short shuttle applications
- Industry leading ergonomic features



Truck Dimensions

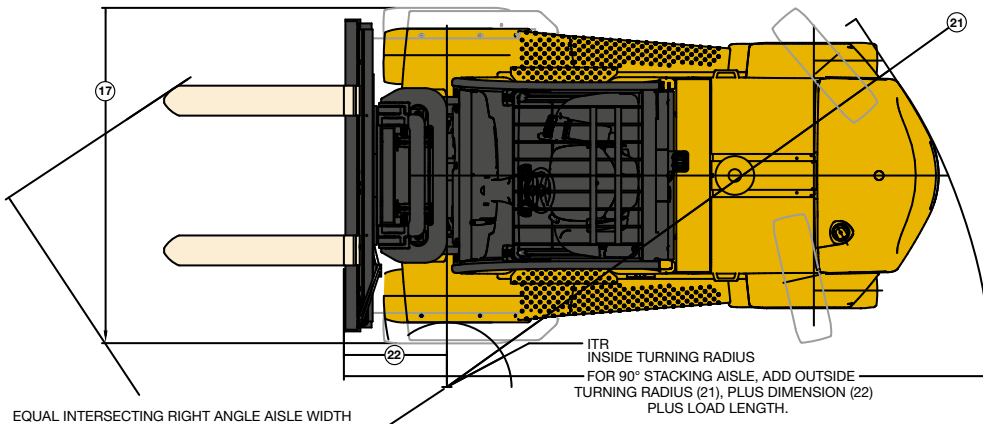

	Non-Susp	Full	Swivel Full
OHG (Std.)	41.9 (1064)	40.8 (1037)	40.8 (1037)
Cab (Opt.)	41.2 (1047)	40.2 (1020)	40.2 (1020)

Dimensions with seat in depressed position.

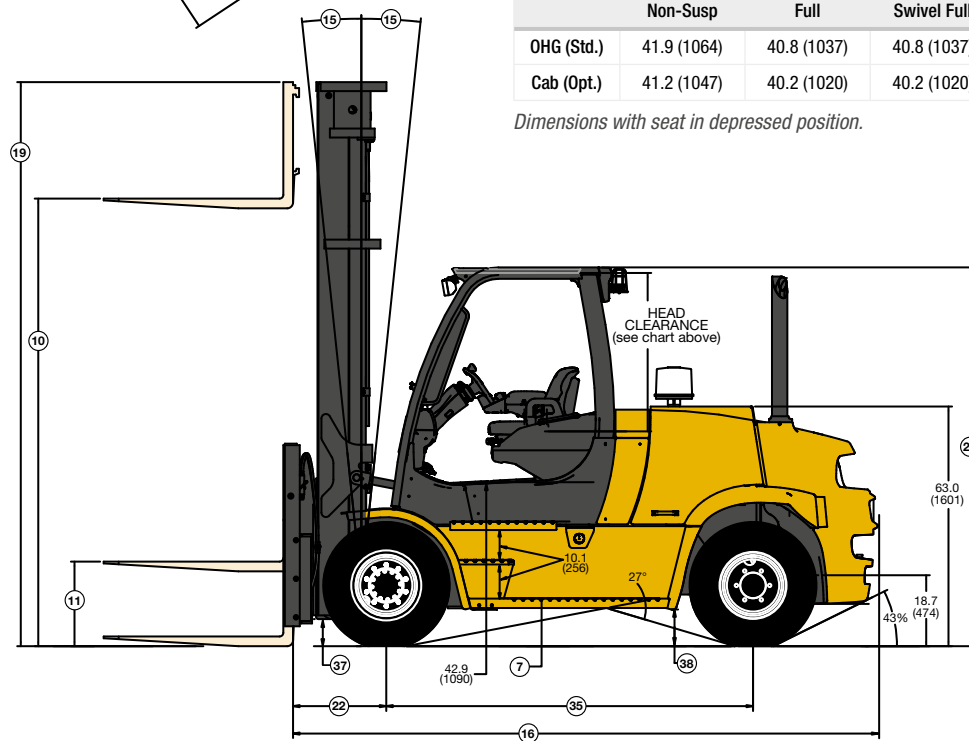

Engine Specifications (High Output)

Kubota 3.8L High Output Tier 4 Turbo Diesel Engine

Cylinders	I-4
Displacement	230 cu.in./3.8 liter
Torque	373 lb.ft. @ 1600 RPM
Horsepower	110 hp @ 2400 RPM
Air Filtration	Two Stage, Dry Type
Emission Control	DPF/SCR Control

Engine Specifications (DOC - Diesel Oxidation Catalyst)

Kubota 3.8L DOC Tier 4 Final Turbo Diesel Engine

Cylinders	I-4
Displacement	230 cu.in./3.8 liter
Torque	227 (309) lb.ft. @ 1400 RPM
Horsepower	74 hp @ 2200 RPM
Air Filtration	Two Stage, Dry Type
Emission Control	DOC Control

General Specifications GP170VX - Diesel, LPG

		Yale®	
GENERAL	1	Manufacturer	GP170VX
	2	Model designation	GP170VX
	2a	Powertrain – engine transmission	Kubota 3.8L DOC Techtronix 332 Kubota 3.8L High Output Techtronix 332
	3	Load capacity	17,000 (8,000)
	4	Load center	24 (600)
	5	Drive power type: gas, diesel, LPG	Diesel
	6	Operation	Seated Rider
	7	Step height (from ground to running board)	12.6 (321)
	7a	Step height (between intermediate steps between running board and floor)	10.1 (256)
DIMENSIONS	8	Tires	Pneumatic
	9	Number of wheels, front/rear (X = driven)	4X/2 ¹
	10	Lift height, w/LBR (TOF) (rounded down)	219 (5565)
	11	Standard free lift height (rounded down)	4 (105)
	12	Fork carriage width – standard carriage	80 ³ (2030 ³)
	12b	Fork spacing - std. carriage - min. inside to inside edge	2.6 (65)
	13	Fork dimensions	7.9 X 2.5 X 47.2 (200 X 65 X 1200)
	13a	Fork carriage to DIN 15173. Class, A/B	IV A
	14	Fork spacing - std. carriage - max. outside to outside edge	78.3 (1990)
	15	Mast tilt, forward / back	5 / 9 ²
	16	Overall length (length to face of forks)	153 (3883)
	17	Overall width	88 (2239)
	18	Height of standard mast, lowered (rounded up)	156 (3962)
	19	Height of mast, extended w/o load backrest (rounded up)	266 (6739)
	19a	Height of mast, extended w/load backrest (rounded up)	270 (6847)
	20	Height to top of standard overhead guard (rounded up)	100 (2531)
	20a	Height to top of cab (rounded up)	101 (2549)
	20b	Towing coupling height	18.7 (476)
	21	Outer turning radius	145 (3673)
	21a	Inner turning radius	14.3 (362)
	22	Load distance (load face-center of wheel to face of forks– front overhang) 2-stage	23.6 (599.5)
	22a	Load distance (load face-center of wheel to face of forks– front overhang) 3-stage	25.6 (650.5)
	22b	Right angle stack (add length of load)	168 (4273)
	23	Right angle stack with pallets 42in wide x 48in long	216 (5492)
24	90° intersecting aisle (with pallet W=42in, L=48in)	120 (3056)	
PERFORMANCE	25a	Travel speed fwd, RL/NL	12.0/13.1 (19.3/21.1)
	25b	Travel speed rev, RL/NL	11.9/12.8 (19.1/20.5)
	26	Lifting speed, standard 2-stage LFL RL/NL	67/67 (.34/.34)
	26a	Lifting speed, optional 3-stage FFL RL/NL	64/67 (.33/.34)
	27	Lowering speed, standard 2-stage LFL RL/NL	81/73 (0.41/0.37)
	27a	Lowering speed, optional 3-stage FFL RL/NL	77/65 (0.39/0.33)
	28	Drawbar pull @ maximum RL/NL	12000/7213 (5443/3272)
	28a	Drawbar pull @ 1 mph RL/NL	11445/7213 (5192/3272)
	28b	Drawbar pull @ 3 mph RL/NL	4444/7213 (2016/3272)
	29	Maximum gradeability RL/NL	29/29
29a	Gradeability @ 1 mph RL/NL	27/29	
29b	Gradeability @ 3 mph RL/NL	11/29	
WT.	31	Weight, standard truck NL	24824 (11260)
	32a	Axle loading, static front/rear NL	12022/12800 (5453/5806)
	32b	Axle loading, static front/rear RL	37509/4314 (17014/1957)
WHEELS & TIRES	33	Tire size – front	8.25 X 15 -14PR ¹
	34	Tire size – rear	8.25 X 15 -14PR ¹
	35	Wheelbase	96.5 (2450)
	37	Ground clearance under mast, laden	6.8 (173)
	38	Ground clearance at center of wheelbase	10.0 (253)
	39	Brakes service – method of control/operation	Hydraulic/Foot
	40	Brakes park – method of control/operation	Mechanical/Hand
TRANS. & POWER UNIT	41	Battery type	Maintenance Free
	42	Battery volts/cold cranking amps	12V / 1010 X 2
	43	Engine manufacturer/type	Kubota 3.8L DOC Kubota 3.8L High Output
	44	Engine power @ governed speed	74 (55) @ 2200RPM 110 (82) @ 2400RPM
	45	Torque @ rated RPM	227 (309) @ 1400RPM 373 (275) @ 1600 RPM
	46	Number of cylinders/displacement	I-4/3769 (230)
	47	Gear change type	Electronically Controlled Powershift
	47a	Transmission: number of speeds forward/reverse	3F / 2R
	48	Fuel tank – capacity	19.8 (74.8)
	49	Working pressure for attachments	2250 (155)
	50	Oil flow for attachments	24 (93)
	51	Towing coupling type	Pin
52	Hydraulic tank – capacity (drain & refill)	18.7 (70.9)	

¹ Other tire options are available.

² Backtilt limited to 6 degrees with some mast options.

³ Carriage is 80" wide, load backrest is 82" wide.

General Specifications GP175VX - Diesel, LPG

GENERAL	1	Manufacturer	Yale®	
	2	Model designation	GP175VX	
	2a	Powertrain – engine transmission	Kubota 3.8L DOC Techtronix 332	Kubota 3.8L High Output Techtronix 332
	3	Load capacity	lbs (kg) 17,500 (8,000)	
	4	Load center	in (mm) 36 (900)	
	5	Drive power type: gas, diesel, LPG	Diesel	
	6	Operation	Seated Rider	
	7	Step height (from ground to running board)	in (mm) 12.6 (321)	
	7a	Step height (between intermediate steps between running board and floor)	in (mm) 10.1 (256)	
DIMENSIONS	8	Tires	Pneumatic	
	9	Number of wheels, front/rear (X = driven)	4X/2 ¹	
	10	Lift height, w/LBR (TOF) (rounded down)	in (mm) 219 (5565)	
	11	Standard free lift height (rounded down)	in (mm) 4 (105)	
	12	Fork carriage width – standard carriage	in (mm) 80 ³ (2030 ³)	
	12b	Fork spacing - std. carriage - min. inside to inside edge	in (mm) 2.6 (65)	
	13	Fork dimensions	in (mm) 7.9 X 2.5 X 47.2 (200 X 65 X 1200)	
	13a	Fork carriage to DIN 15173. Class, A/B	class IV A	
	14	Fork spacing - std. carriage - max. outside to outside edge	in (mm) 78.3 (1990)	
	15	Mast tilt, forward / back	degrees 5 / 9 ²	
	16	Overall length (length to face of forks)	in (mm) 159 (4038)	
	17	Overall width	in (mm) 88 (2239)	
	18	Height of standard mast, lowered (rounded up)	in (mm) 156 (3962)	
	19	Height of mast, extended w/o load backrest (rounded up)	in (mm) 266 (6739)	
	19a	Height of mast, extended w/load backrest (rounded up)	in (mm) 270 (6847)	
	20	Height to top of standard overhead guard (rounded up)	in (mm) 100 (2531)	
	20a	Height to top of cab (rounded up)	in (mm) 101 (2549)	
	20b	Towing coupling height	in (mm) 18.7 (476)	
	21	Outer turning radius	in (mm) 149 (3794)	
	21a	Inner turning radius	in (mm) 14.3 (362)	
	22	Load distance (load face-center of wheel to face of forks– front overhang) 2-stage	in (mm) 23.6 (599.5)	
	22a	Load distance (load face-center of wheel to face of forks– front overhang) 3-stage	in (mm) 25.6 (650.5)	
	22b	Right angle stack (add length of load)	in (mm) 173 (4394)	
	23	Right angle stack with pallets 42in wide x 48in long	in (mm) 221 (5613)	
24	90° intersecting aisle (with pallet W=42in, L=48in)	in (mm) 123 (3126)		
PERFORMANCE	25a	Travel speed fwd, RL/NL	mph (km/hr) 11.9/13.1 (19.1/21.0)	13.3/14.4 (21.5/23.2)
	25b	Travel speed rev, RL/NL	mph (km/hr) 11.8/12.7 (19.0/20.5)	10.6/11.5 (17.1/18.6)
	26	Lifting speed, standard 2-stage LFL RL/NL	ft/min (m/sec) 64/67 (.32/.34)	86/89 (.44/.34)
	26a	Lifting speed, optional 3-stage FFL RL/NL	ft/min (m/sec) 61/67 (.31/.34)	84/89 (.43/.34)
	27	Lowering speed, standard 2-stage LFL RL/NL	ft/min (m/sec) 81/73 (0.41/0.37)	
	27a	Lowering speed, optional 3-stage FFL RL/NL	ft/min (m/sec) 77/65 (0.39/0.33)	
	28	Drawbar pull @ maximum RL/NL	lbs (kg) 12000/7213 (5443/3272)	12000/7213 (5443/3272)
	28a	Drawbar pull @ 1 mph RL/NL	lbs (kg) 11401/7213 (5171/3272)	12000/7213 (5443/3272)
	28b	Drawbar pull @ 3 mph RL/NL	lbs (kg) 4399/7213 (1996/3272)	7989/7213 (3624/3272)
29	Maximum gradeability RL/NL	% 27/29 27/29		
29a	Gradeability @ 1 mph RL/NL	% 26/29 27/29		
29b	Gradeability @ 3 mph RL/NL	% 29/29 18/29		
WT.	31	Weight, standard truck NL	lbs (kg) 26782 (12148)	
	32a	Axle loading, static front/rear NL	lbs (kg) 11367/15415 (5156/6992)	
	32b	Axle loading, static front/rear RL	lbs (kg) 39778/4502 (18043/2042)	
WHEELS & TIRES	33	Tire size – front	8.25 X 15 -14PR ¹	
	34	Tire size – rear	8.25 X 15 -14PR ¹	
	35	Wheelbase	in (mm) 96.5 (2450)	
	37	Ground clearance under mast, laden	in (mm) 6.8 (173)	
	38	Ground clearance at center of wheelbase	in (mm) 10.0 (253)	
	39	Brakes service – method of control/operation	Hydraulic/Foot	
	40	Brakes park – method of control/operation	Mechanical/Hand	
TRANS. & POWER UNIT	41	Battery type	Maintenance Free	
	42	Battery volts/cold cranking amps	12V / 1010 X 2	
	43	Engine manufacturer/type	Kubota 3.8L DOC	Kubota 3.8L High Output
	44	Engine power @ governed speed	hp (kw) 74 (55) @ 2200RPM	110 (82) @ 2400RPM
	45	Torque @ rated RPM	ft. lbs (N-m) 227 (309) @ 1400RPM	373 (275) @ 1600 RPM
	46	Number of cylinders/displacement	No./cc (ci) I-4/3769 (230)	
	47	Gear change type	Electronically Controlled Powershift	
	47a	Transmission: number of speeds forward/reverse	3F / 2R	
	48	Fuel tank – capacity	gal (liters) 19.8 (74.8)	
	49	Working pressure for attachments	psi (bar) 2250 (155)	
	50	Oil flow for attachments	gal/min (l/min) 24 (93)	
	51	Towing coupling type	Pin	
52	Hydraulic tank – capacity (drain & refill)	gal (liters) 18.7 (70.9)		

¹ Other tire options are available.

² Backtilt limited to 6 degrees with some mast options.

³ Carriage is 80" wide, load backrest is 82" wide.

General Specifications GP190VX - Diesel, LPG

GENERAL	1	Manufacturer		Yale®	
	2	Model designation		GP190VX	
	2a	Powertrain – engine transmission		Kubota 3.8L DOC Techtronix 332	Kubota 3.8L High Output Techtronix 332
	3	Load capacity	lbs (kg)	19,000 (9,000)	
	4	Load center	in (mm)	24 (600)	
	5	Drive power type: gas, diesel, LPG		Diesel	
	6	Operation		Seated Rider	
	7	Step height (from ground to running board)	in (mm)	12.6 (321)	
	7a	Step height (between intermediate steps between running board and floor)	in (mm)	10.1 (256)	
DIMENSIONS	8	Tires		Pneumatic	
	9	Number of wheels, front/rear (X = driven)		4X/2 ¹	
	10	Lift height, w/LBR (TOF) (rounded down)	in (mm)	219 (5565)	
	11	Standard free lift height (rounded down)	in (mm)	4 (105)	
	12	Fork carriage width – standard carriage	in (mm)	80 ³ (2030 ³)	
	12b	Fork spacing - std. carriage - min. inside to inside edge	in (mm)	2.6 (65)	
	13	Fork dimensions	in (mm)	7.9 X 2.5 X 47.2 (200 X 65 X 1200)	
	13a	Fork carriage to DIN 15173. Class, A/B	class	IV A	
	14	Fork spacing - std. carriage - max. outside to outside edge	in (mm)	78.3 (1990)	
	15	Mast tilt, forward / back	degrees	5 / 9°	
	16	Overall length (length to face of forks)	in (mm)	156 (3958)	
	17	Overall width	in (mm)	88 (2239)	
	18	Height of standard mast, lowered (rounded up)	in (mm)	156 (3962)	
	19	Height of mast, extended w/o load backrest (rounded up)	in (mm)	266 (6739)	
	19a	Height of mast, extended w/load backrest (rounded up)	in (mm)	270 (6847)	
	20	Height to top of standard overhead guard (rounded up)	in (mm)	100 (2531)	
	20a	Height to top of cab (rounded up)	in (mm)	101 (2549)	
	20b	Towing coupling height	in (mm)	18.7 (476)	
	21	Outer turning radius	in (mm)	147 (3723)	
	21a	Inner turning radius	in (mm)	14.3 (362)	
	22	Load distance (load face-center of wheel to face of forks– front overhang) 2-stage	in (mm)	23.6 (599.5)	
	22a	Load distance (load face-center of wheel to face of forks– front overhang) 3-stage	in (mm)	25.6 (650.5)	
	22b	Right angle stack (add length of load)	in (mm)	170 (4323)	
	23	Right angle stack with pallets 42in wide x 48in long	in (mm)	218 (5542)	
24	90° intersecting aisle (with pallet W=42in, L=48in)	in (mm)	121 (3085)		
PERFORMANCE	25a	Travel speed fwd, RL/NL	mph (km/hr)	11.9/13.0 (19.2/21.0)	13.4/14.4 (21.5/23.2)
	25b	Travel speed rev, RL/NL	mph (km/hr)	11.8/12.7 (19.1/20.5)	10.7/11.5 (17.2/18.5)
	26	Lifting speed, standard 2-stage LFL RL/NL	ft/min (m/sec)	54/67 (.27/.34)	78/89 (.40/.34)
	26a	Lifting speed, optional 3-stage FFL RL/NL	ft/min (m/sec)	50/67 (.26/.34)	75/89 (.38/.34)
	27	Lowering speed, standard 2-stage LFL RL/NL	ft/min (m/sec)	81/73 (0.41/0.37)	
	27a	Lowering speed, optional 3-stage FFL RL/NL	ft/min (m/sec)	77/65 (0.39/0.33)	
	28	Drawbar pull @ maximum RL/NL	lbs (kg)	12000/7213 (5443/3272)	12000/7213 (5443/3272)
	28a	Drawbar pull @ 1 mph RL/NL	lbs (kg)	11433/7213 (5186/3272)	12000/7213 (5443/3272)
	28b	Drawbar pull @ 3 mph RL/NL	lbs (kg)	4431/7213 (2010/3272)	8021/7213 (3638/3272)
29	Maximum gradeability RL/NL	%	27/29	27/29	
29a	Gradeability @ 1 mph RL/NL	%	25/29	27/29	
29b	Gradeability @ 3 mph RL/NL	%	10/29	18/29	
WT.	31	Weight, standard truck NL	lbs (kg)	25857 (11729)	
	32a	Axle loading, static front/rear NL	lbs (kg)	11693/14162 (5304/6424)	
	32b	Axle loading, static front/rear RL	lbs (kg)	40179/4678 (18225/2122)	
WHEELS & TIRES	33	Tire size – front		8.25 X 15 -14PR ¹	
	34	Tire size – rear		8.25 X 15 -14PR ¹	
	35	Wheelbase	in (mm)	96.5 (2450)	
	37	Ground clearance under mast, laden	in (mm)	6.8 (173)	
	38	Ground clearance at center of wheelbase	in (mm)	10.0 (253)	
	39	Brakes service – method of control/operation		Hydraulic/Foot	
	40	Brakes park – method of control/operation		Mechanical/Hand	
TRANS. & POWER UNIT	41	Battery type		Maintenance Free	
	42	Battery volts/cold cranking amps		12V / 1010 X 2	
	43	Engine manufacturer/type		Kubota 3.8L DOC	Kubota 3.8L High Output
	44	Engine power @ governed speed	hp (kw)	74 (55) @ 2200RPM	110 (82) @ 2400RPM
	45	Torque @ rated RPM	ft. lbs (N-m)	227 (309) @ 1400RPM	373 (275) @ 1600 RPM
	46	Number of cylinders/displacement	No./cc (ci)	I-4/3769 (230)	
	47	Gear change type		Electronically Controlled Powershift	
	47a	Transmission: number of speeds forward/reverse		3F / 2R	
	48	Fuel tank – capacity	gal (liters)	19.8 (74.8)	
	49	Working pressure for attachments	psi (bar)	2250 (155)	
	50	Oil flow for attachments	gal/min (l/min)	24 (93)	
	51	Towing coupling type		Pin	
52	Hydraulic tank – capacity (drain & refill)	gal (liters)	18.7 (70.9)		

¹ Other tire options are available.

² Backtilt limited to 6 degrees with some mast options.

³ Carriage is 80" wide, load backrest is 82" wide.

GP170-190VX Mast dimensions

Maximum Fork Height (TOF)	Overall Lowered Height	Overall Extended Height		Free-Lift (TOF)		Approx. Total Wt. of Std. Equipped Truck		
		w/ Load Backrest	w/o Load Backrest	w/ Load Backrest	w/o Load Backrest	GP170VX with NL	GP175VX with NL	GP190VX with NL
in (mm)	in (mm)	in (mm)	in (mm)	in (mm)	in (mm)	lbs (kg)	lbs (kg)	lbs (kg)
2-Stage Limited Free-Lift (LFL) Mast								
140 (3565)	117 (2962)	191 (4850)	186 (4725)	4 (105)	4 (105)	23361 (11050)	26592 (12062)	25395 (11519)
179 (4565)	137 (3462)	231 (5850)	226 (5725)	4 (105)	4 (105)	24590 (11154)	26821 (12166)	25624 (11623)
219 (5565)	156 (3962)	270 (6850)	265 (6725)	4 (105)	4 (105)	24822 (11259)	27053 (12271)	25856 (11728)
3-Stage Full Free-Lift (FFL) Mast								
181 (4615)	107 (2702)	240 (6077)	235 (5952)	56 (1440)	61 (1565)	25216 (11438)	27447 (12450)	26250 (11907)
234 (5965)	125 (3152)	293 (7427)	288 (7302)	74 (1890)	79 (2015)	25527 (11579)	27758 (12591)	26561 (12048)
Heavy Duty 2-Stage Limited Free-Lift (LFL) Mast								
179 (4565)	137 (3462)	231 (5850)	226 (5725)	4 (105)	4 (105)	24943 (11314)	27174 (12326)	25977 (11783)
219 (5565)	156 (3962)	270 (6850)	265(6725)	4 (105)	4 (105)	25344 (11496)	27575 (12508)	26378 (11965)
Heavy Duty 3-Stage Full Free-Lift (FFL) Mast								
258 (6565)	133 (3362)	317 (8037)	312 (7912)	82 (2090)	87 (2215)	26052 (11817)	33711 (15291)	27086 (12286)

RL = Rated Load NL = No Load

Note: GP170-190VX use standard 8.25 x 15 x 14 PR pneumatic drive tires @ 82.0 inch (2082 mm) overall width.

Options

- Powertrain protection system with engine shutdown
- Premium monitoring package
- Integral sidsifter, and integral sidsifting fork positioner
- Accumulator
- Keyless start (with auxiliary key switch)
- LED brake and back-up lights
- Headlights and rear drive lights with halogen bulbs
- Headlights and rear drive lights with LED bulbs
- Traction speed limiter
- Return-to-set tilt
- Integral operator's cab
- Rear drive handle with horn button
- Swivel full-suspension vinyl and cloth seats
- High-visibility non-cinch seat belt with or without interlock
- Foot Directional Control pedal
- Impact monitor
- Operator password
- Alarm-reverse actuated 82-102 Db(A) – self-adjusting
- LED amber strobe light - keyswitch activated
- Solid and radial tires
- 4 function (2 aux) hydraulic control valve
- 5° forward/6° backward tilt
- UL type DS
- Fire extinguisher
- Lifting eyes
- Kubota 3.8L High Output Engine (110 HP)



Yale® Veracitor® GP-VX Series

The Veracitor® GP170-190VX truck is designed to meet and exceed your materials handling application requirements with excellent performance and low hourly cost of operation.

Engines

The Kubota 3.8L High Output Tier 4 Final turbo diesel engine and the standard Kubota 3.8L DOC Tier 4 Final turbo diesel engine both utilize a two piece cylinder block for outstanding durability while reducing engine noise. Cylinders are cast into the block for optimum durability and cooling efficiency. Cylinder heads feature a helical, 4-valve "Crossflow" design within each cylinder to create additional airflow into the cylinder for added power. The turbocharger is of a simple design, but uses a variable waste-gate to ensure the proper amount of boost at all engine speeds. Both engines are certified to EPA Tier 4 Final emissions standards.

Fuel System

The Kubota 3.8L DOC Tier 4 Final turbo diesel, and the Kubota 3.8L High Output Tier 4 Final turbo diesel engine fuel systems utilize an electronically controlled, high-pressure common-rail fuel system that sends five separate fuel deliveries per fuel injection power stroke for maximum power and efficiency while reducing the noise levels. The 3.8L High Output engine features a cooled exhaust to be re-burned, which helps reduce emissions. A Diesel Particulate Filter (DPF) captures particulates or "soot" and oxidizes the material to eliminate smoke from the exhaust. A separate display module is furnished to monitor and control the emissions system. The standard Kubota 3.8L DOC Tier 4 Final Turbo diesel engine features a maintenance free emissions system and requires no DPF or SCR.

Transmissions

The standard Techtronix 332 transmission features three speeds forward and two speeds in reverse for excellent gradeability and drawbar pull while allowing top travel speeds for maximum productivity. Auto Deceleration feature is accomplished through the controlled application of the clutch packs. Controlled power reversals are managed by precisely regulating engine speed to reduce driveline stress during directional changes. Inching is controlled electronically. This transmission also features electronic shift control, smooth electronic inching, neutral start switch, and anti-restart protection. A single pedal controls both inching and braking. Optional dual inch/brake pedals are available for operators who prefer this design. A 100 mesh suction and 10 micron return line filtration protect the transmission from abrasive contaminants.

Cooling System

The cooling system employs a modular radiator system, with sections for engine coolant, transmission oil, and engine intake (charge) air.

An 18" diameter blade pusher-type fan provides cooling air flow. A permanently lubricated water pump and a high capacity, cross-flow radiator ensure rapid heat dissipation. The sealed cooling system operates at a pressure of 15 psi and includes a coolant recovery tank for visual inspection of coolant level. The radiator is soft-mounted for excellent durability.

Drive Axle

The drive axles are designed to withstand heavy loads and absorb shocks. The wheel hubs rotate on large tapered roller bearings. The drive shaft transmits rotational torque to the drive axle from the engine and transmission. Transmission torque is distributed through planetary gear reduction and an industrial hypoid ring gear and pinion assembly.

The drive axle is a "self contained" assembly that is isolated from the transmission by the drive shaft and heavy duty rubber isolators. The axle shafts utilize a "rolled fillet" root spline design for increased resistance to torsion stress. A magnetic sump plug is used to collect any metal particles that are circulating in the axle oil, preventing component wear.

Oil-cooled wet disc brakes

Oil-cooled wet disc brakes are standard and internal to the axle for better protection against the elements. These low pedal effort brakes require no adjustments and very little maintenance, yet provide an extremely long service life.

Metered hydraulic oil pressure is used to actuate the wet disc brakes via a brake-pedal actuated modulating valve. This system yields consistent pedal travel for optimum control. Independent, hand adjustable parking brake with pushbutton release has an audible alarm to indicate when the operator has left the truck without applying the parking brake.

Hydraulic Power Steering

Hydraulic Power Steering (hydrostatic steering) provides responsive control and eliminates mechanical linkages for reduced surface shock and simplified maintenance. The steering wheel is 12 inches in diameter with a textured surface grip and spinner knob, and requires only four turns lock-to-lock. The center mounted steer cylinder is located within the confines of the steer axle for protection.

Steer Axle

Constructed of cast ductile iron and mounted on phenolic bushings, allows the steer axle excellent stability and axle articulation. The steer axle system features tapered spindle bearings and non-adjustable tie rod ends for durability.

Chassis

Designed by state-of-the-art finite element methods, the chassis features inch-thick frame members and contains a rugged, unitized

frame structure with a low step for simple entrance to the operator's compartment. Ergonomically designed overhead guard is bar type for excellent visibility and reduced noise. Gull wing doors on both the right and left sides provide excellent service access.

Operator's Compartment

The operator compartment features Accutouch minilever, electro-hydraulic controls integrated into the operator's right-side armrest allowing superior ergonomic actuation. Automotive-style pedal arrangement with a large, single inch/brake pedal is standard. Rubber floor mat reduces noise and vibration. The floorplate can be removed without tools for excellent service access. Low step height and a convenient hand grip provide easy entry and exit to and from the truck.

Intellix VSM

Intellix VSM acts as a master truck controller, providing extensive monitoring and control of truck functions and systems. CANbus technology reduces wiring complexity and enables comprehensive communications between truck systems. The ergonomically positioned dash display transmits continual feedback to the operator and allows for communication of service codes. Comprehensive on-board diagnostics enable quick and easy troubleshooting. The electrical system features sealed connectors and Hall Effect sensors for superior dependability.

Hydraulic System

Incorporating a gear type pump with a cast iron body for quiet efficiency, the hydraulic system is protected from overloads by a main relief valve for the lift circuit and a secondary relief valve for tilt and auxiliary functions. Oil is double filtered through a 100 mesh suction line strainer and 10 micron return line filter. The hydraulic tank is integrated into the frame. An emergency lowering valve is provided to allow the load to be lowered in the event of power loss. O-ring face seal fittings are used in all high pressure hydraulic connections.

Yale® Masts

Yale masts are available in Simplex LFL (Limited Free Lift) and Triplex FFL (Full Free Lift) models. The mast features pre-lubed and sealed full-radius load rollers that resist the forward, rearward and lateral forces. Side-thrust wear pads allow for periodic adjustments for lateral clearances. The rolled mast channels are made of high-strength steel to provide resistance to flaring of the channel flanges. 80" wide hook-type carriages are standard equipment, providing great visibility and handles a wide variety of forks and attachments.

The optional heavy duty mast provides a solution for users in extreme applications that require heavy attachment use or frequently moved maximum rated loads.



YALE MATERIALS HANDLING CORPORATION • P.O. Box 7367, Greenville, NC 27835-7367

www.yale.com Manufactured in our own ISO 9001 and 14001 Registered Facilities

Yale is a Registered Trademark and  is a Registered Copyright. ©Yale Materials Handling Corporation 2017. All Rights Reserved.

Truck performance may be affected by the condition of the vehicle, how it is equipped and the application. Consult your Yale® Industrial Truck Dealer if any of the information shown is critical to your application. Specifications are subject to change without notice. CERTIFICATION: Yale lift trucks meet the design and construction requirements of B56.1-1969, per OSHA Section 1910.178(a)(2), and also comply with the B56.1 revision in effect at time of manufacture. Certification of compliance with the applicable ANSI standards appears on the lift truck. The Yale® products included in this document may be covered by US patent 6,684,148 and other patents pending.